



NST
NILES
STEEL
TANK
 SINCE 1898

MODEL # JS-42-105

Design Notes

Code..... ASME Sec IV HLW
 Design Pressure..... 125 psi
 Test Pressure..... 125 psi
 Interior.... Ultonium® Glass Lining with Microban®
 Exterior..... Baked Enamel Steel Jacket
 Insulation..... 2" R-12.5 Open Cell Foam
 Supports..... 2" Rails
 Capacity..... 575 Gal./ 630 nominal
 Weight..... 1292 Lbs.

Material Specifications

Heads..... Carbon Steel
 Shell..... Carbon Steel
 Couplings..... Carbon Steel
 Flanges..... N/A
 Pipe..... N/A
 Manway..... Carbon Steel
 Jacket..... 24 Gauge Steel

Microban® antimicrobial product protection helps prevent the growth of bacteria, mold and mildew that may affect the product. The built-in antimicrobial properties do not protect users or others from disease-causing organisms. Microban® is a registered trademark of Microban Products Company.

Mark	Dimension	Remark
A	113"	Overall height
B	46"	Diameter
C	22.5"	Circulation

NOTES
PROJECT
CUSTOMER
SCALE Not to Scale
DATE
CUSTOMER P.O. #
DRAWING Rev NO.

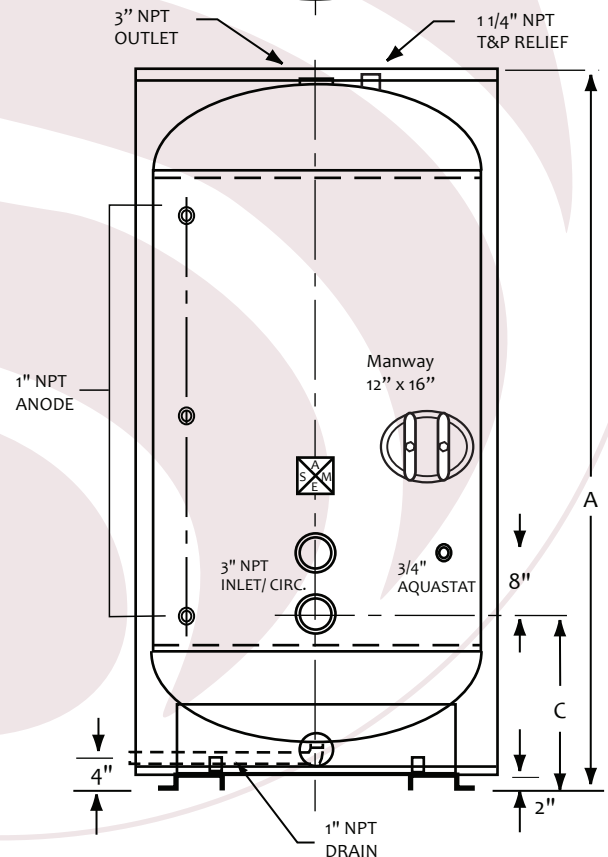
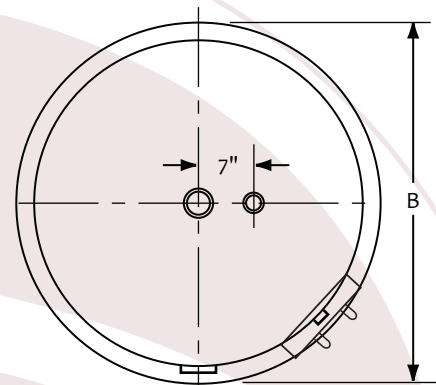

VERTICAL STORAGE TANK