



NST
NILES
STEEL
TANK
SINCE 1898
898

MODEL # JS-32-200

Design Notes

Code..... ASME Sec IV HLW
 Design Pressure..... 150psi
 Test Pressure..... 150psi
 Interior.... Ultonium® Glass Lining with Microban®
 Exterior..... Baked Enamel Steel Jacket
 Insulation..... 2" R-12.5 Open Cell Foam
 Supports..... Sits on Shell
 Capacity..... 200 Gal.
 Weight..... 541Lbs.

Material Specifications

Heads..... Carbon Steel
 Shell..... Carbon Steel
 Couplings..... Carbon Steel
 Flanges..... N/A
 Pipe..... N/A
 Jacket..... 24 Gauge Steel

Microban® antimicrobial product protection helps prevent the growth of bacteria, mold and mildew that may affect the product. The built-in antimicrobial properties do not protect users or others from disease-causing organisms. Microban® is a registered trademark of Microban Products Company.

**** No modifications can be made to this tank**

Mark	Dimension	Remark
A	78"	Overall height
B	77"	Top of Jacket
C	32"	Diameter
D	66"	T&P to Floor
E	16 1/4"	Circulation
F	11 1/4"	Circulation

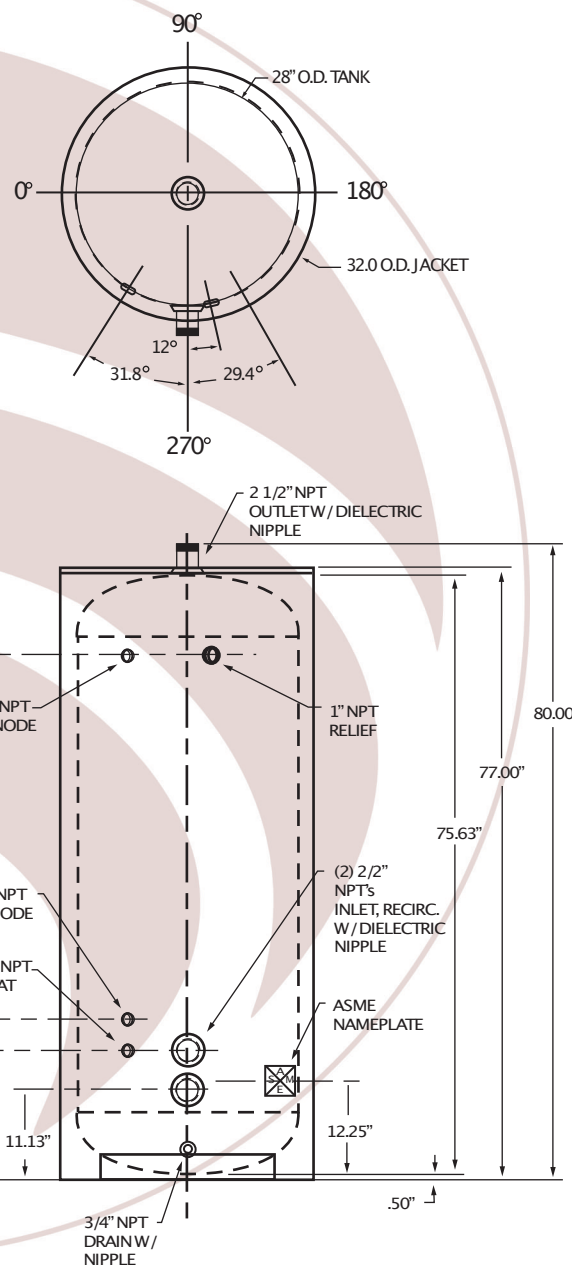

THIS DWG HAS BEEN FURNISHED BY NILES STEEL TANK CO. THE INFORMATION AND KNOW HOW THEREON MAY NOT BE USED NOR THE DWG REPRODUCED WITHOUT THE WRITTEN PERMISSION OF NILES STEEL TANK CO. ALL REPRODUCTION IN WHOLE OR IN PART, INCLUDING VENDORS' SHOP DWGS SHALL BEAR OR REFER TO THIS STAMP.