



NST
NILES
STEEL
TANK
SINCE 1898

MODEL # JS-24-080A

Design Notes

Code..... ASME Sec IV HLW
 Design Pressure..... 150 psi
 Test Pressure..... 150 psi
 Interior.... Ultonium® Glass Lining with Microban®
 Exterior..... Baked Enamel Steel Jacket
 Insulation..... 2" R-12.5 Open Cell Foam
 Supports..... Sits on Shell
 Capacity..... 80 Gal.
 Weight..... 192 Lbs.

Material Specifications

Heads..... Carbon Steel
 Shell..... Carbon Steel
 Couplings..... Carbon Steel
 Flanges..... N/A
 Pipe..... N/A
 Manway..... N/A
 Jacket..... 24 Gauge Steel

Microban® antimicrobial product protection helps prevent the growth of bacteria, mold and mildew that may affect the product. The built-in antimicrobial properties do not protect users or others from disease-causing organisms. Microban® is a registered trademark of Microban Products Company.

2" NPT
Hot Out

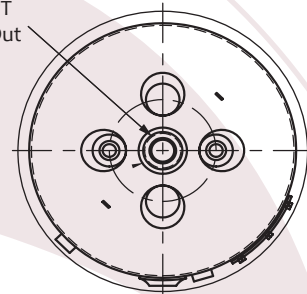

**** No modifications can be made to this tank**

Mark	Dimension	Remark
A	59 3/4"	Overall height
B	58 3/4"	Top of Jacket
C	24"	Diameter
D	52 1/2"	T&P to Floor
E	9 1/4"	Circulation
F	14 1/4"	Circulation

NOTES	
PROJECT	
CUSTOMER	
SCALE	Not to Scale
DATE	
CUSTOMER P.O. #	
DRAWING Rev NO.	

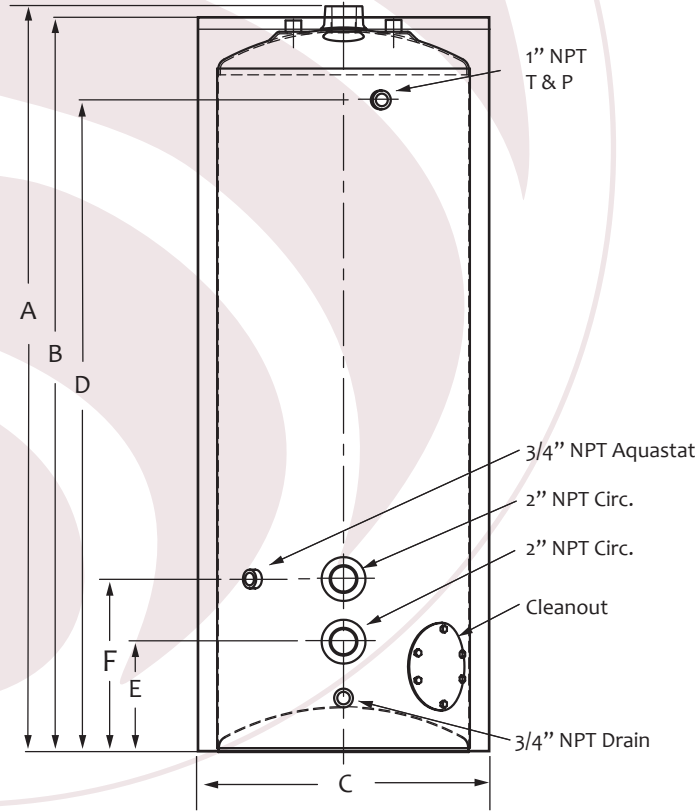

VERTICAL STORAGE TANK