



NST
NILES
STEEL
TANK
SINCE 1898

MODEL # JS-20-050

Design Notes

Code..... Non-Code
 Design Pressure..... 150 psi
 Test Pressure..... 150 psi
 Interior.... Ultonium® Glass Lining with Microban®
 Exterior..... Baked Enamel Steel Jacket
 Insulation..... 2" R-12.5 Open Cell Foam
 Supports..... Sits on Shell
 Capacity..... 50 Gal.
 Weight..... 130 Lbs.

Material Specifications

Heads..... Carbon Steel
 Shell..... Carbon Steel
 Couplings..... Carbon Steel
 Flanges..... N/A
 Pipe..... N/A
 Manway..... N/A
 Jacket..... 24 Gauge Steel

Microban® antimicrobial product protection helps prevent the growth of bacteria, mold and mildew that may affect the product. The built-in antimicrobial properties do not protect users or others from disease-causing organisms. Microban® is a registered trademark of Microban Products Company.

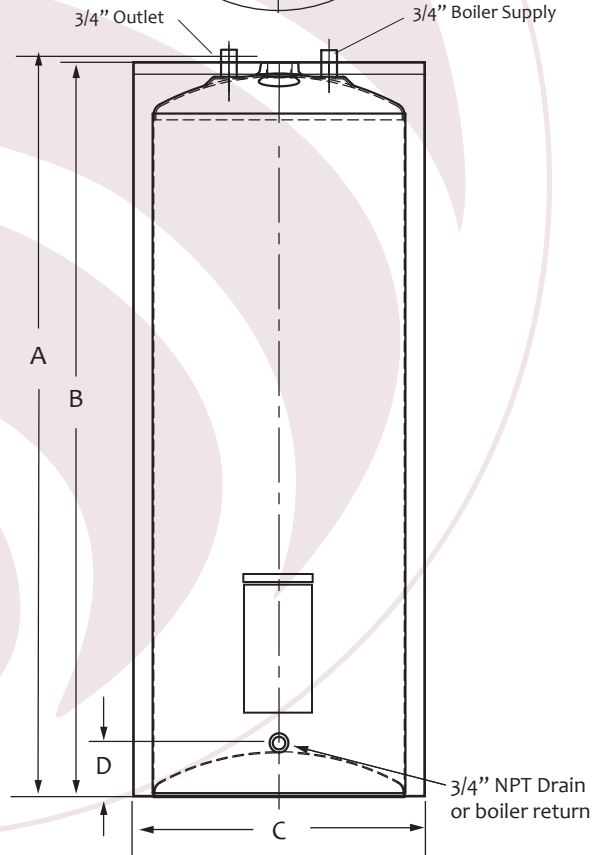
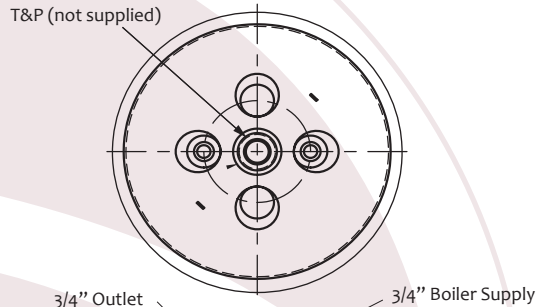

VERTICAL STORAGE TANK

**** No modifications can be made to this tank**

Mark	Dimension	Remark
A	47 5/16"	Overall height
B	46 5/16"	Top of Jacket
C	22"	Diameter
D	3 1/16"	Drain

NOTES	
PROJECT	
CUSTOMER	
SCALE	Not to Scale
DATE	
CUSTOMER P.O. #	
DRAWING Rev NO.	