



# MODEL # JH-48-120

**NST**  
**NILES**  
**STEEL**  
**TANK**  
SINCE 1898

## Design Notes

Code..... ASME Sec IV HLW  
 Design Pressure..... 125 psi  
 Test Pressure..... 125 psi  
 Interior.... Ultonium® Glass Lining with Microban®  
 Exterior..... Baked Enamel Steel Jacket  
 Insulation..... 2" R-12 Open cell foam  
 Supports..... Saddles  
 Capacity..... 860 Gal. / 940 nominal  
 Weight..... 2069 Lbs.

## Material Specifications

Heads..... Carbon Steel  
 Shell..... Carbon Steel  
 Jacket..... 24 Gauge Steel  
 Couplings..... Carbon Steel  
 Flanges..... N/A  
 Pipe..... N/A  
 Manway..... Carbon Steel

Microban® antimicrobial product protection helps prevent the growth of bacteria, mold and mildew that may affect the product. The built-in antimicrobial properties do not protect users or others from disease-causing organisms. Microban® is a registered trademark of Microban Products Company.

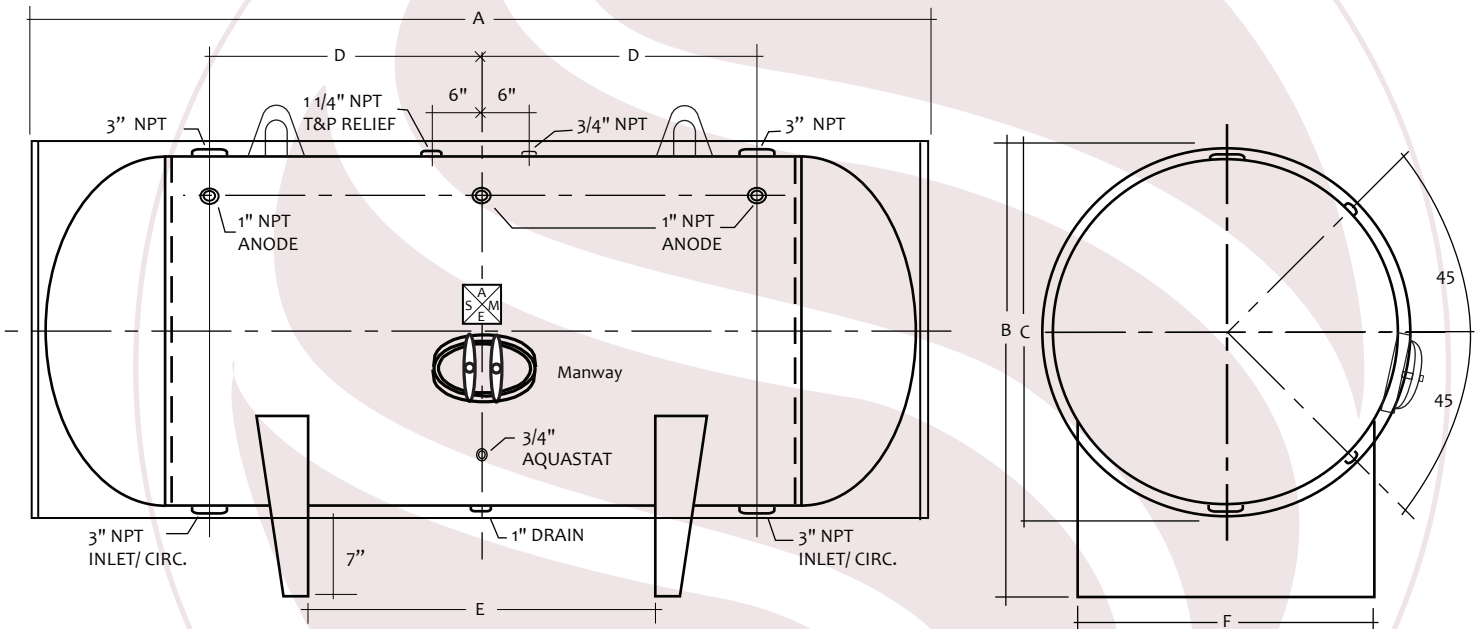

HORIZONTAL STORAGE TANK

Mark	Dimension	Remark	NOTES
A	124"	Overall length	PROJECT
B	59"	Overall height	CUSTOMER
C	52"	Diameter	SCALE Not to Scale
D	42"	Circulation	DATE
E	60"	Supports	CUSTOMER P.O. #
F	42.13"	Support width	DRAWING Rev NO.