



MODEL # JH-42-093

NST
NILES
STEEL
TANK
SINCE 1898

Design Notes

Code..... ASME Sec IV HLW
 Design Pressure..... 125 psi
 Test Pressure..... 125 psi
 Interior.... Ultonium® Glass Lining with Microban®
 Exterior..... Baked Enamel Steel Jacket
 Insulation..... 2" R-12 Open cell foam
 Supports..... Saddles
 Capacity..... 505 Gal. / 558 nominal
 Weight..... 1181 Lbs.

Material Specifications

Heads..... Carbon Steel
 Shell..... Carbon Steel
 Jacket..... 24 Gauge Steel
 Couplings..... Carbon Steel
 Flanges..... N/A
 Pipe..... N/A
 Manway..... Carbon Steel

Microban® antimicrobial product protection helps prevent the growth of bacteria, mold and mildew that may affect the product. The built-in antimicrobial properties do not protect users or others from disease-causing organisms. Microban® is a registered trademark of Microban Products Company.

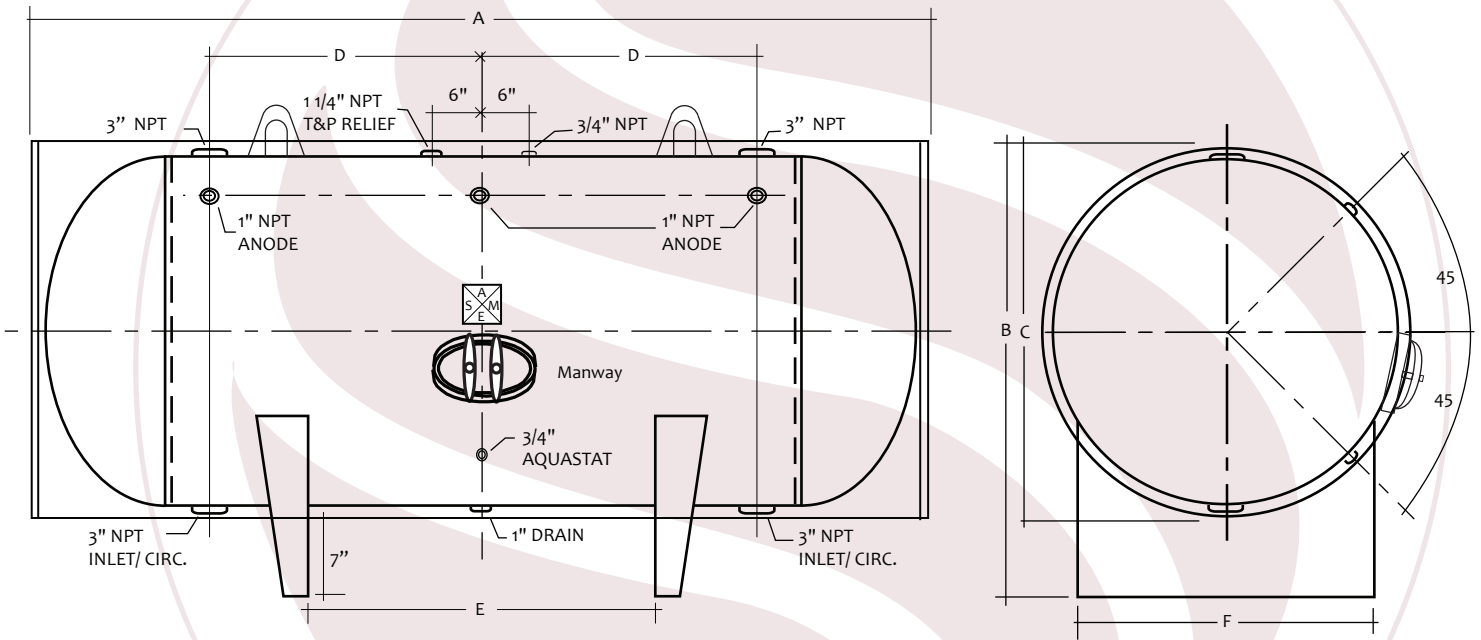

HORIZONTAL STORAGE TANK

| Mark | Dimension | Remark | NOTES |
|------|-----------|----------------|--------------------|
| A | 97" | Overall length | PROJECT |
| B | 53" | Overall height | CUSTOMER |
| C | 46" | Diameter | SCALE Not to Scale |
| D | 30" | Circulation | DATE |
| E | 36" | Supports | CUSTOMER P.O. # |
| F | 36.75" | Support width | DRAWING Rev NO. |