



NST
NILES
STEEL
TANK
SINCE 1898

MODEL # BH-48-073

Design Notes

Code..... ASME Sec IV HLW
 Design Pressure..... 125 psi
 Test Pressure..... 125 psi
 Interior.... Ultonium® Glass Lining with Microban®
 Exterior..... Primed Painted
 Supports..... Saddles
 Capacity..... 500 Gal. / 572 nominal
 Weight..... 1090 Lbs.

Material Specifications

Heads..... Carbon Steel
 Shell..... Carbon Steel
 Couplings..... Carbon Steel
 Flanges..... N/A
 Pipe..... N/A
 Manway..... Carbon Steel

Microban® antimicrobial product protection helps prevent the growth of bacteria, mold and mildew that may affect the product. The built-in antimicrobial properties do not protect users or others from disease-causing organisms. Microban® is a registered trademark of Microban Products Company.

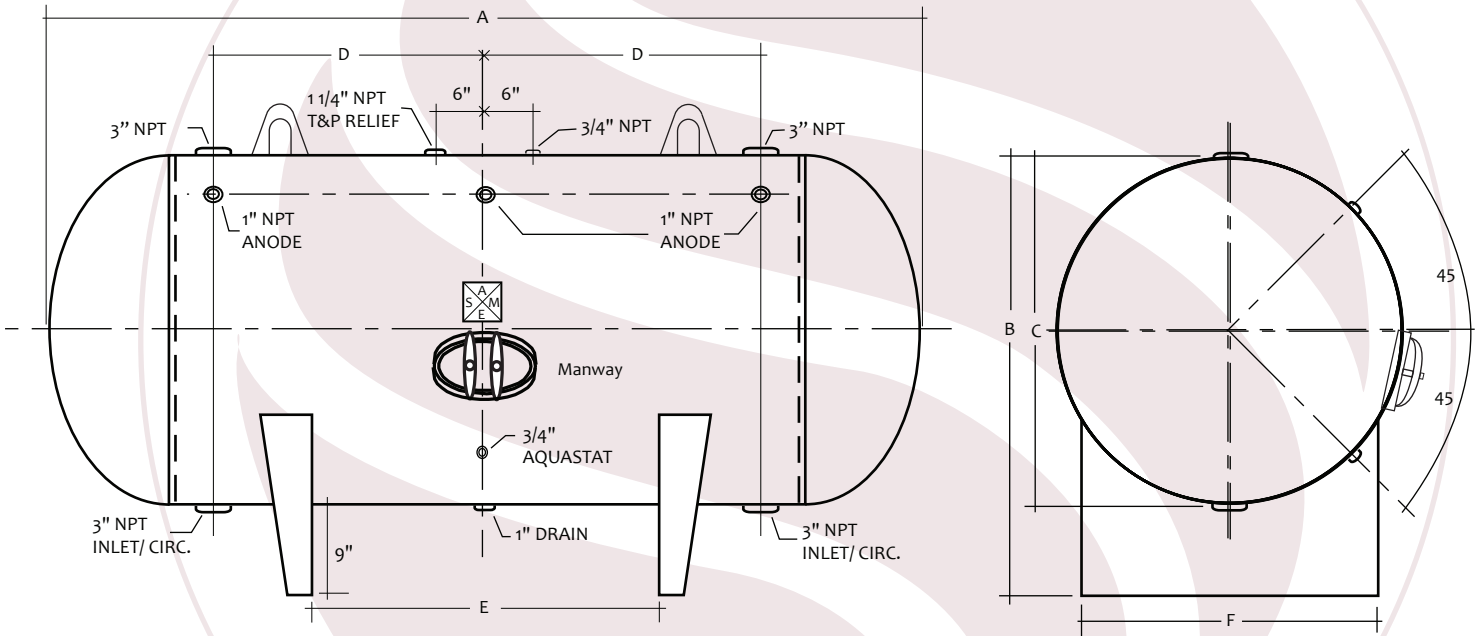

HORIZONTAL STORAGE TANK

| Mark | Dimension | Remark |
|------|-----------|----------------|
| A | 73" | Overall length |
| B | 57" | Overall height |
| C | 48" | Diameter |
| D | 18.5" | Circulation |
| E | 17" | Supports |
| F | 42.13" | Support width |

| NOTES | |
|-----------------|--------------|
| PROJECT | |
| CUSTOMER | |
| SCALE | Not to Scale |
| DATE | |
| CUSTOMER P.O. # | |
| DRAWING Rev NO. | |