



**NST**  
**NILES**  
**STEEL**  
**TANK**  
SINCE 1898

# MODEL # BH-36-102

## Design Notes

Code..... ASME Sec IV HLW  
 Design Pressure..... 125 psi  
 Test Pressure..... 125 psi  
 Interior.... Ultonium® Glass Lining with Microban®  
 Exterior..... Primed Painted  
 Supports..... Saddles  
 Capacity..... 415 Gal. / 449 nominal  
 Weight..... 768 Lbs.

## Material Specifications

Heads..... Carbon Steel  
 Shell..... Carbon Steel  
 Couplings..... Carbon Steel  
 Flanges..... N/A  
 Pipe..... N/A  
 Manway..... N/A

Microban® antimicrobial product protection helps prevent the growth of bacteria, mold and mildew that may affect the product. The built-in antimicrobial properties do not protect users or others from disease-causing organisms. Microban® is a registered trademark of Microban Products Company.

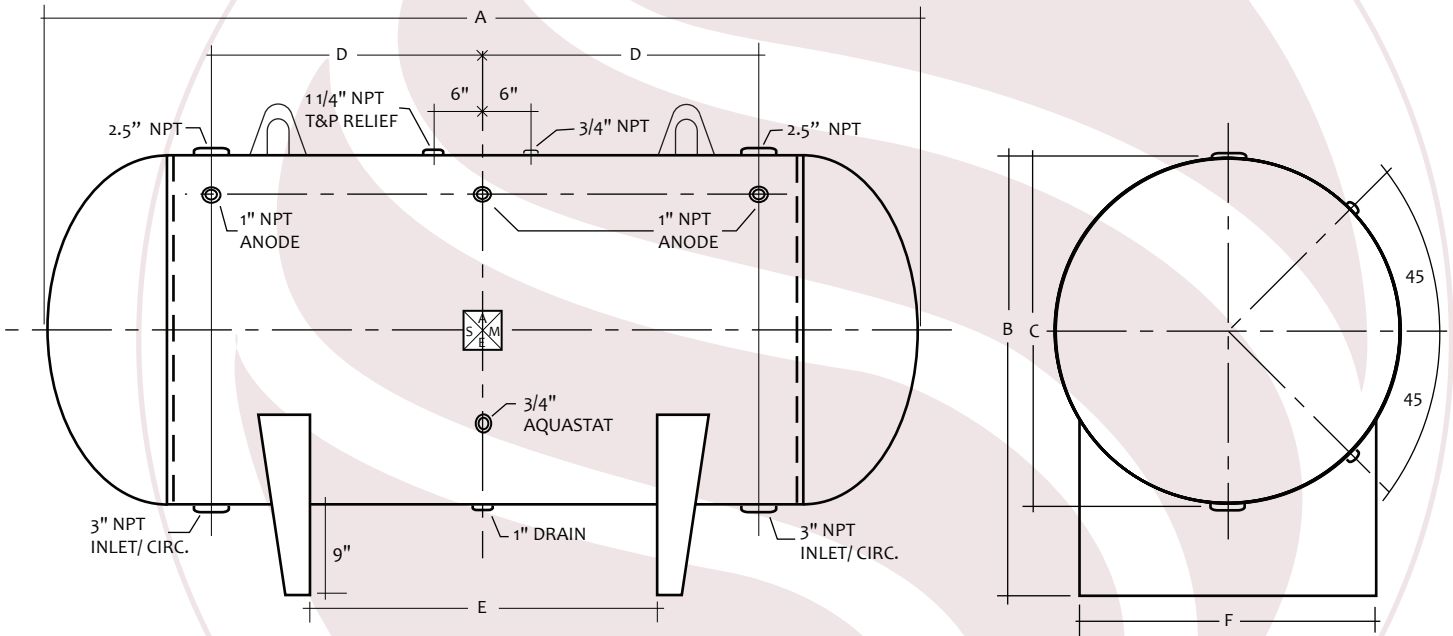

HORIZONTAL STORAGE TANK

| Mark | Dimension | Remark         |
|------|-----------|----------------|
| A    | 102"      | Overall length |
| B    | 45"       | Overall height |
| C    | 36"       | Diameter       |
| D    | 36"       | Circulation    |
| E    | 48"       | Supports       |
| F    | 31.69"    | Support width  |

| NOTES           |              |
|-----------------|--------------|
| PROJECT         |              |
| CUSTOMER        |              |
| SCALE           | Not to Scale |
| DATE            |              |
| CUSTOMER P.O. # |              |
| DRAWING Rev NO. |              |