



**NST**  
**NILES**  
**STEEL**  
**TANK**  
SINCE 1898

# MODEL # BH-36-090

## Design Notes

Code..... ASME Sec IV HLW  
 Design Pressure..... 125 psi  
 Test Pressure..... 125 psi  
 Interior.... Ultonium® Glass Lining with Microban®  
 Exterior..... Primed Painted  
 Supports..... Saddles  
 Capacity..... 360 Gal. / 397 nominal  
 Weight..... 690 Lbs.

## Material Specifications

Heads..... Carbon Steel  
 Shell..... Carbon Steel  
 Couplings..... Carbon Steel  
 Flanges..... N/A  
 Pipe..... N/A  
 Manway..... N/A

Microban® antimicrobial product protection helps prevent the growth of bacteria, mold and mildew that may affect the product. The built-in antimicrobial properties do not protect users or others from disease-causing organisms. Microban® is a registered trademark of Microban Products Company.

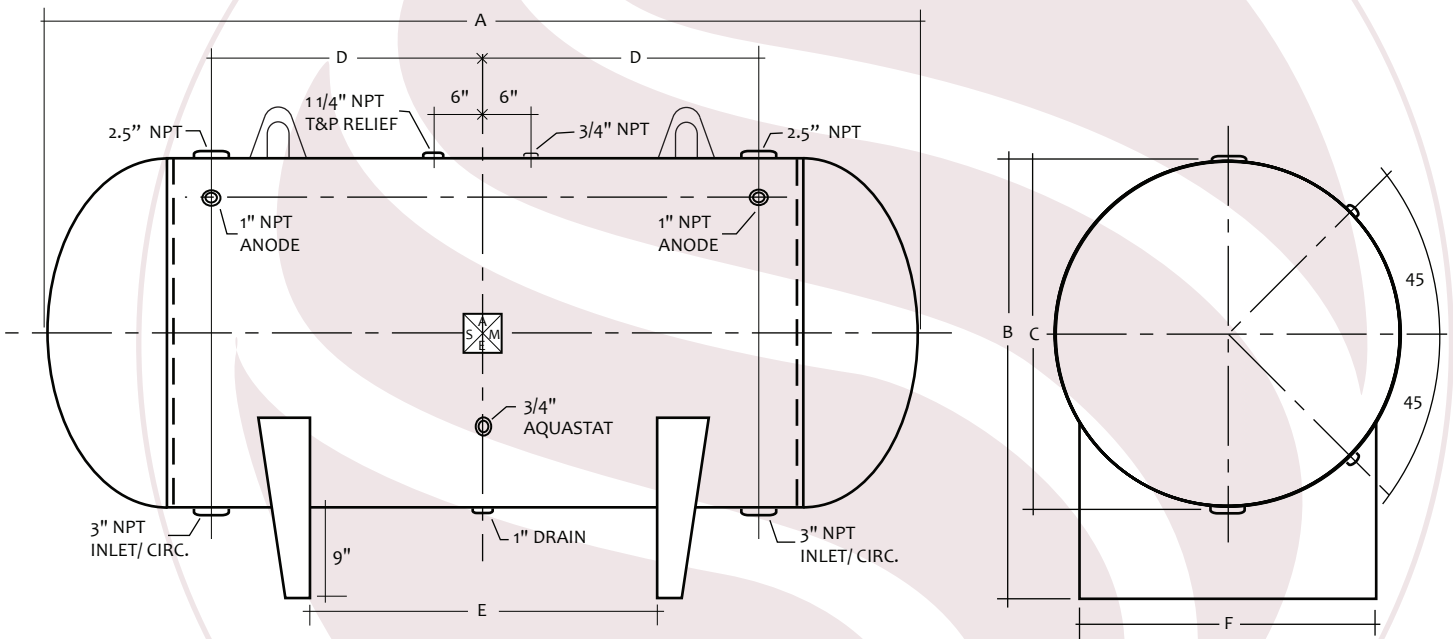

HORIZONTAL STORAGE TANK

Mark	Dimension	Remark
A	90"	Overall length
B	45"	Overall height
C	36"	Diameter
D	30"	Circulation
E	36"	Supports
F	31.69"	Support width

NOTES
PROJECT
CUSTOMER
SCALE Not to Scale
DATE
CUSTOMER P.O. #
DRAWING Rev NO.