

CUSTOMER:

XXXX

CONSTRUCTION:

MATERIAL - CARBON STEEL
INTERIOR LINING - GLASS
EXTERIOR - RED OXIDE PRIMER
M.A.W.P. - 125 PSI
MAX. OPERATING TEMP. - 180°F

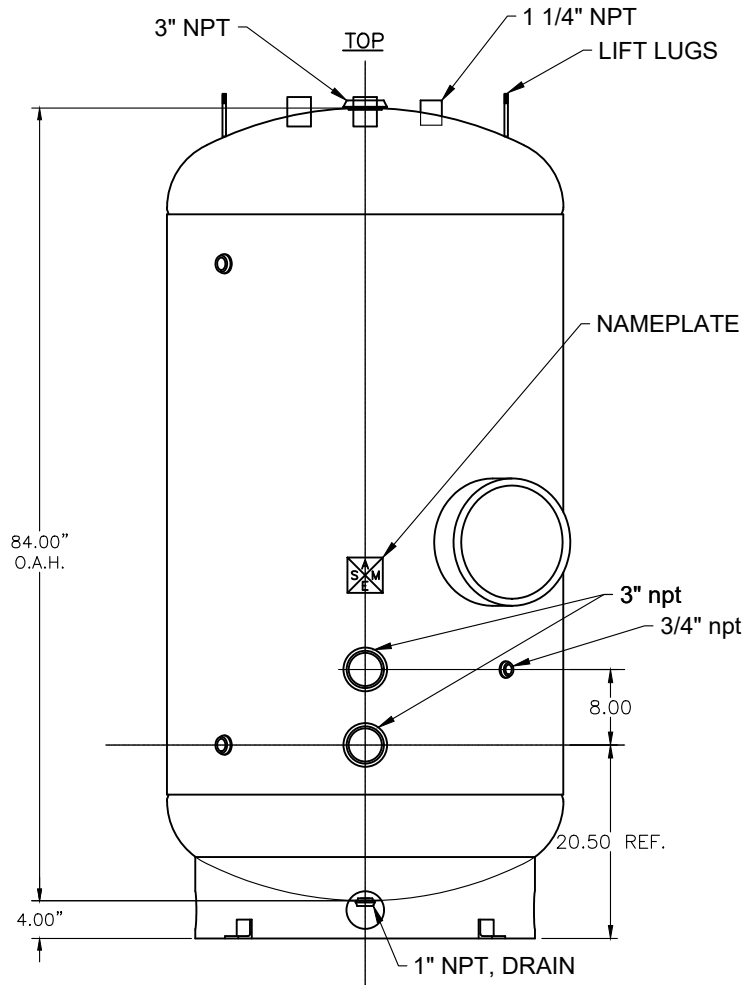
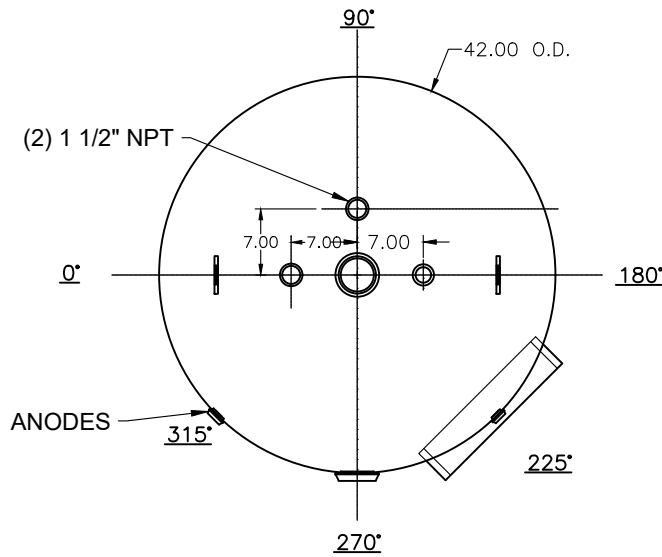

THIS DWG HAS BEEN FURNISHED BY NILES STEEL TANK CO. THE INFORMATION AND KNOW HOW THEREON MAY NOT BE USED NOR THE DWG REPRODUCED WITHOUT THE WRITTEN PERMISSION OF NILES STEEL TANK CO. ALL REPRODUCTION IN WHOLE OR IN PART, INCLUDING VENDORS' SHOP DWGS SHALL BEAR OR REFER TO THIS STAMP.

HOT WATER STORAGE TANK
MODEL# CHICAGO S 42 084 SPL
42" DIA., 453 GALLON
ASME VI, 125 PSI



QUOTE NUMBER: XXXX	DRAWN BY: DB 1/5/22	APPROVED BY:	
DWG. NUMBER CHICAGO S 42 084 SPL		SCALE NONE	REV. A

1701 Terminal Road
Niles, Michigan 49120
Ph: (269) 683-1910
Fax: (269) 683-1953
email: info@nilesst.com