

CUSTOMER:

XXXX

CONSTRUCTION:
 MATERIAL - CARBON STEEL
 INTERIOR LINING - NONE
 EXTERIOR - RED OXIDE PRIMER
 M.A.W.P. - 125 PSI
 MAX. OPERATING TEMP. - 400°F

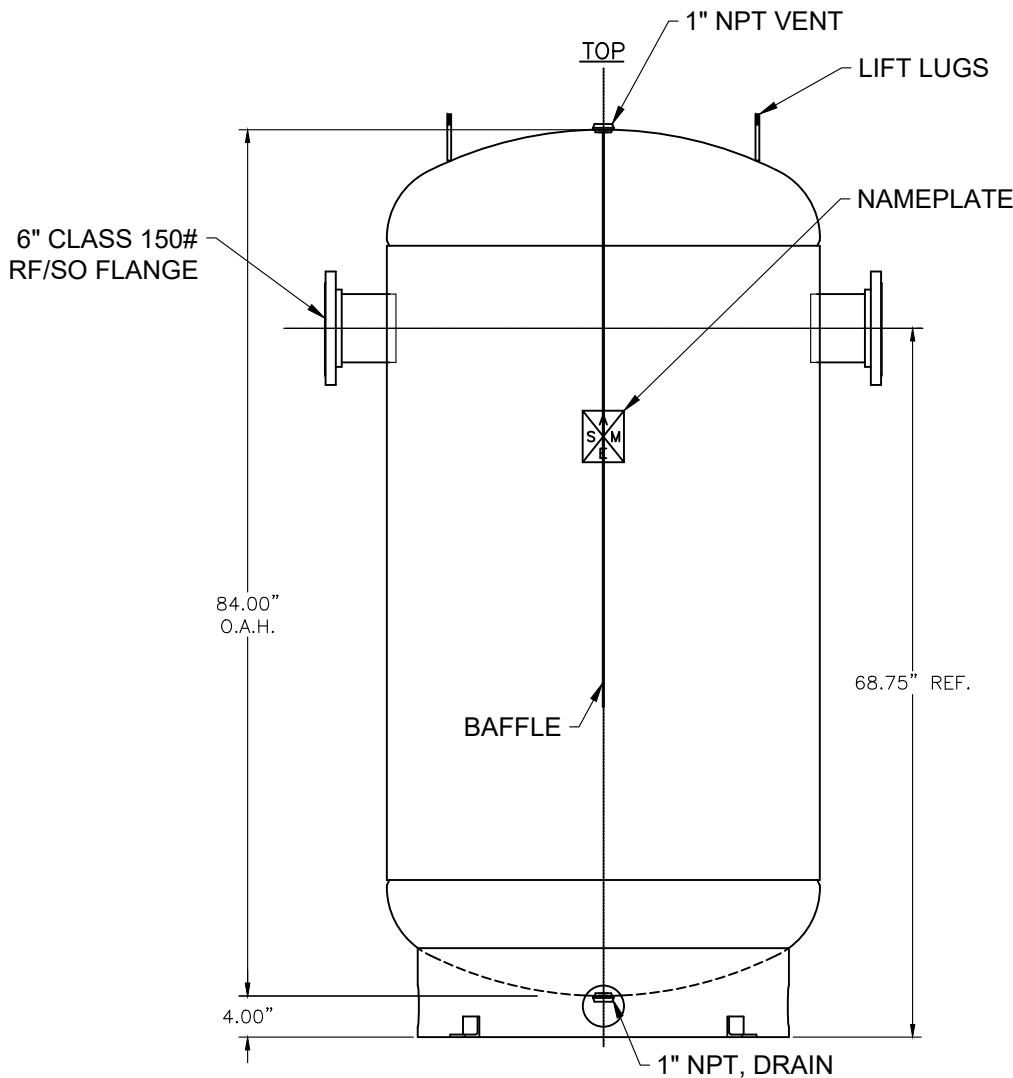

THIS DWG HAS BEEN FURNISHED BY NILES STEEL TANK CO. THE INFORMATION AND KNOW HOW THEREON MAY NOT BE USED NOR THE DWG REPRODUCED WITHOUT THE WRITTEN PERMISSION OF NILES STEEL TANK CO. ALL REPRODUCTION IN WHOLE OR IN PART, INCLUDING VENDORS' SHOP DWGS SHALL BEAR OR REFER TO THIS STAMP.

CHILLED WATER BUFFER TANK
 MODEL# CBT-42 084 6F
 42" DIA., 460 GALLON
 ASME VIII, DIV.1, 125 PSI



QUOTE NUMBER: XXXX	DRAWN BY: DB 2/26/21	APPROVED BY:	
DWG. NUMBER CBT-42-084-6F		SCALE NONE	REV. A

1701 Terminal Road
 Niles, Michigan 49120
 Ph: (269) 683-1910
 Fax: (269) 683-1953
 email: info@nilesst.com