



NST
NILES
STEEL
TANK
SINCE 1898

MODEL # CBT-36-090

Design Notes

Code..... ASME Section VIII Div 1
 Design Pressure..... 125 psi
 Test Pressure..... 163 psi
 Interior.....None
 Exterior.....Primed Painted
 Supports.....Skirt
 Capacity..... 360 Gal.
 Weight..... 715 Lbs.

Material Specifications

Heads..... Carbon Steel
 Shell..... Carbon Steel
 Couplings..... Carbon Steel
 Flanges..... N/A
 Pipe..... N/A
 Manway..... Optional

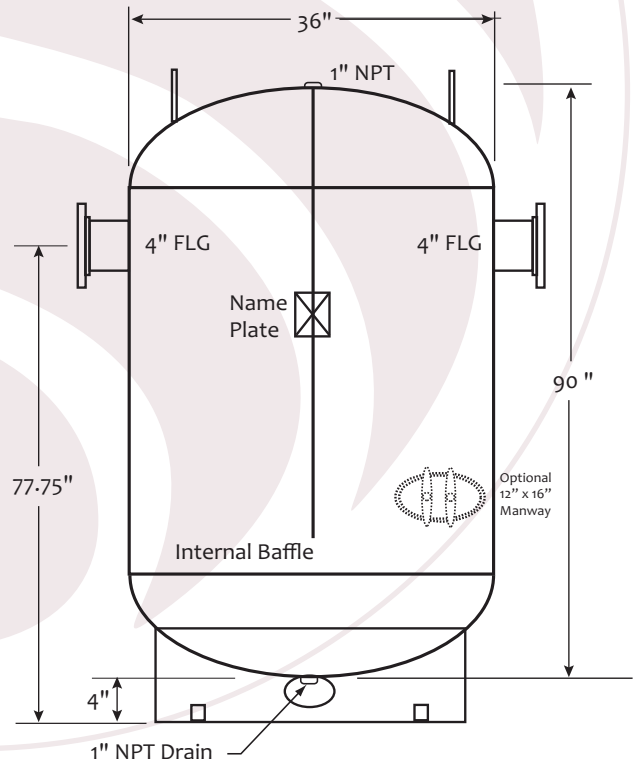
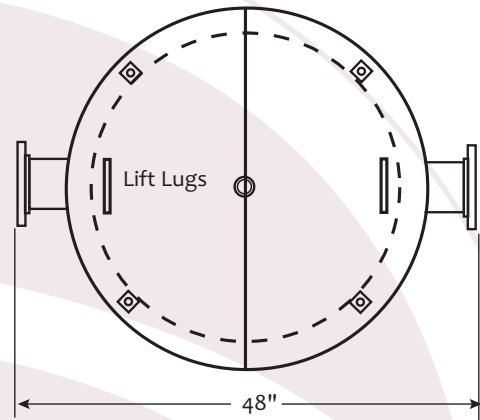

NOTES	

PROJECT	
CUSTOMER	
SCALE	Not to Scale
DATE	
CUSTOMER P.O. #	
DRAWING Rev NO.	