



MODEL # CBT-42-090

NST
NILES
STEEL
TANK
SINCE 1898

Design Notes

Code..... ASME Section VIII Div 1
Design Pressure..... 125 psi
Test Pressure..... 163 psi
Interior..... None
Exterior..... Prime Painted
Supports..... Skirt
Capacity..... 500 Gal.
Weight..... 1300 Lbs.

Material Specifications

Heads..... Carbon Steel
Shell..... Carbon Steel
Couplings..... Carbon Steel
Flanges..... N/A
Pipe..... N/A
Manway..... Optional

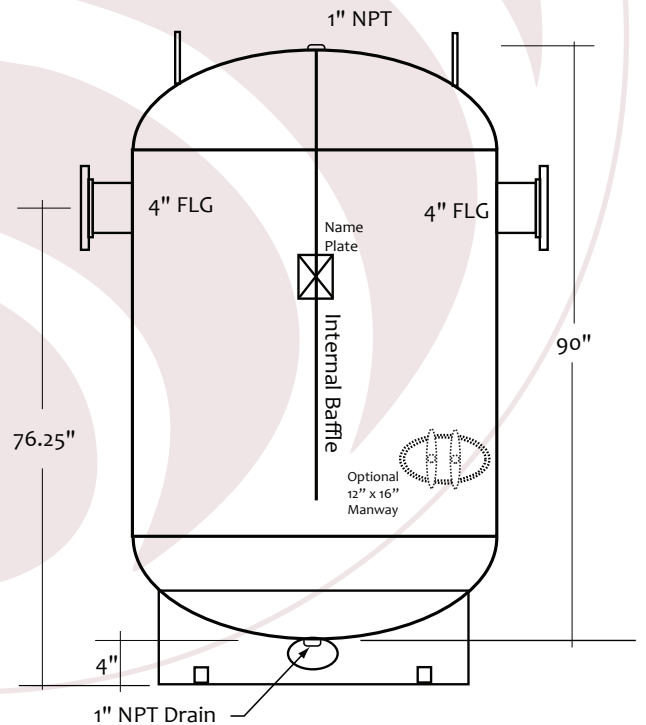
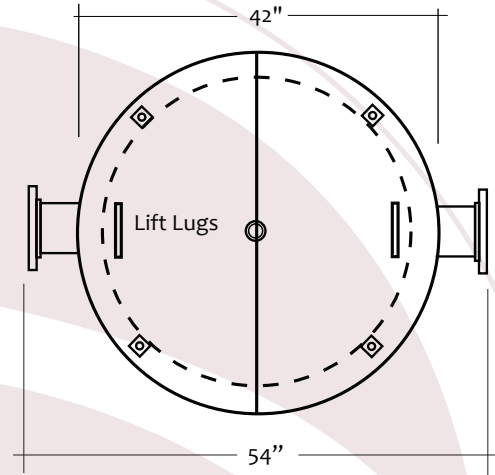

NOTES

PROJECT	
CUSTOMER	
SCALE	Not to Scale
DATE	
CUSTOMER P.O. #	
DRAWING Rev NO.	