



**Niles Steel Tank Hot Water Generator
Installation and Operation Manual**

Contents:

Contents.....	1
Hazard definitions.....	1
1. General Information.....	2
Availability.....	3
Optional Control Packages	5
2. Installation.....	7
3. Operation.....	11
a. Start-up Procedure.....	11
b. Shut-down Procedure.....	12
4. Inspection.....	13
5. Troubleshooting.....	14
6. Maintenance.....	17
a. Storage Tank Maintenance.....	17
b. Components Replacement.....	20
7. Notes.....	27

Hazard Definitions:

The following defined terms are used throughout this manual to bring attention to the presence of hazards of risk levels or to important information concerning the life of the product.

DANGER

DANGER indicates an imminently hazardous situation which, if not avoided, will result in death or serious injury.

WARNING

WARNING indicates a potentially hazardous situation which, if not avoided, will result in death or serious injury.

CAUTION

CAUTION indicates a potentially hazardous situation which, if not avoided, may result in minor or moderate injury.

CAUTION

CAUTION used without the safety alert symbol indicates a potentially hazardous situation which, if not avoided may result in property damage.

NOTICE

NOTICE indicates special instructions on installation, operation or maintenance that are important but not related to personal injury or property damage.

1. GENERAL INFORMATION

WARNING

- Before using product, read and understand instructions.
- Save these instruction for future reference.
- All work must be performed by qualified personnel trained in the proper application, installation and maintenance of steam systems and/or boiler water systems in accordance with all applicable codes and ordinances.
- To prevent serious burns, wear heat resistant gloves when opening and closing steam valves or handling hot equipment.
- To prevent serious burns the internal pressure of the trap must be at 0 psi (0 bar) before servicing.
- To prevent serious personal injury from steam pipe blow down, connect a temporary pipe between the steam pipe opening and a drain, or stand at least 100 ft. (30 m) from the front of the pipe opening.
- To prevent property damage, personal injury or death, cap off the gate valves if they are not in use for test or pressure relief.

Failure to follow this warning could cause property damage, personal injury or death.

This manual is intended to cover installation, operation and maintenance procedures for Niles Steel Tank Hot Water Generator Systems. Since each unit is built to meet customers specifications, instructions may not be specific to every system.

If questions are not answered by this manual, or if specific installation, operation or maintenance procedures are not clearly understood, contact Niles Steel Tank for clarification before proceeding.

These Hot Water Generator Systems are designed for indoor use only unless otherwise required by design specifications. Each unit requires at least two (2) feet of clearance around and above the unit. It should be located on a level surface (no more than ½ degree of slope) capable of supporting the total weight of the unit when filled to capacity.

The unit should be mounted to the floor following applicable architectural and local code requirement for this specific installation site. Note: Tanks do not come standard with floor tie-downs.

The high quality enamel paint applied to the jacket of the unit will provide years of protection against corrosion. If it is necessary to clean the outside of the unit, a mild cleaning agent should be used that will not damage the paint.

For all piping connections the use and/ or type of joint compound or sealer on the joints should be determined by referring to local codes accepted standards and/ or the requirements of the installing contractor.

Hot Water Generators use steam or boiler water as an energy source.

Availability:

Hot Water Generators are pre-engineered and pre-assembled complete with all piping to meet your specific application.

Hot Water Generator Systems are available in horizontal or vertical configurations (see FIG.'s 1 & 2) in a wide array of gallon capacities. Standard packages are available in tank sizes from 200 – 1000 gallons with single wall copper tube bundle heating units. Custom configurations, smaller and larger tank and bundles and optional control packages are also available. Consult factory for specifications.

Tank Construction – Niles Steel Tank's are available with Ultonium premium glass lining or Niles Defender Epoxy lining.

ASME – All Niles Steel Tank's are constructed in accordance with ASME standards.

Cathodic Protection – All Ultonium glass lined and Niles Defender Epoxy lined are equipped with magnesium anodes to provide protection against corrosion.

Manway- A manway is provided as an option on Ultonium glass lined tanks. Manways are standard on all Niles Defender Epoxy lined tanks.

Tank Circulation Package – Optional circulation pump package to optimize heat transfer.

Five-Year Limited Tank Warranty – Provides warranty protection against tank failure (see warranty for details)

One-Year Limited Warranty –Parts, accessories and controls (see warranty for details)

Figure 1 Vertical Tanks

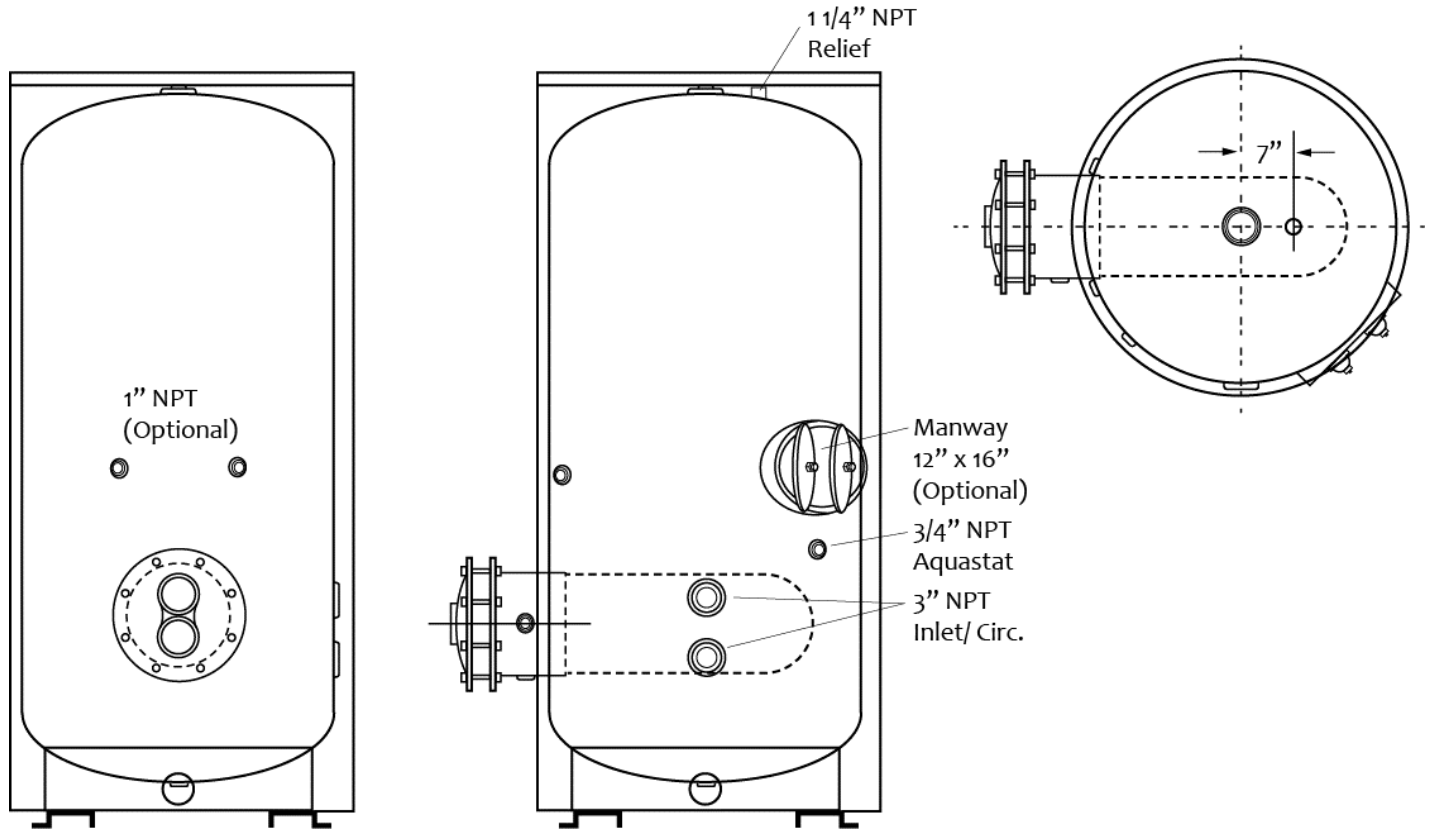
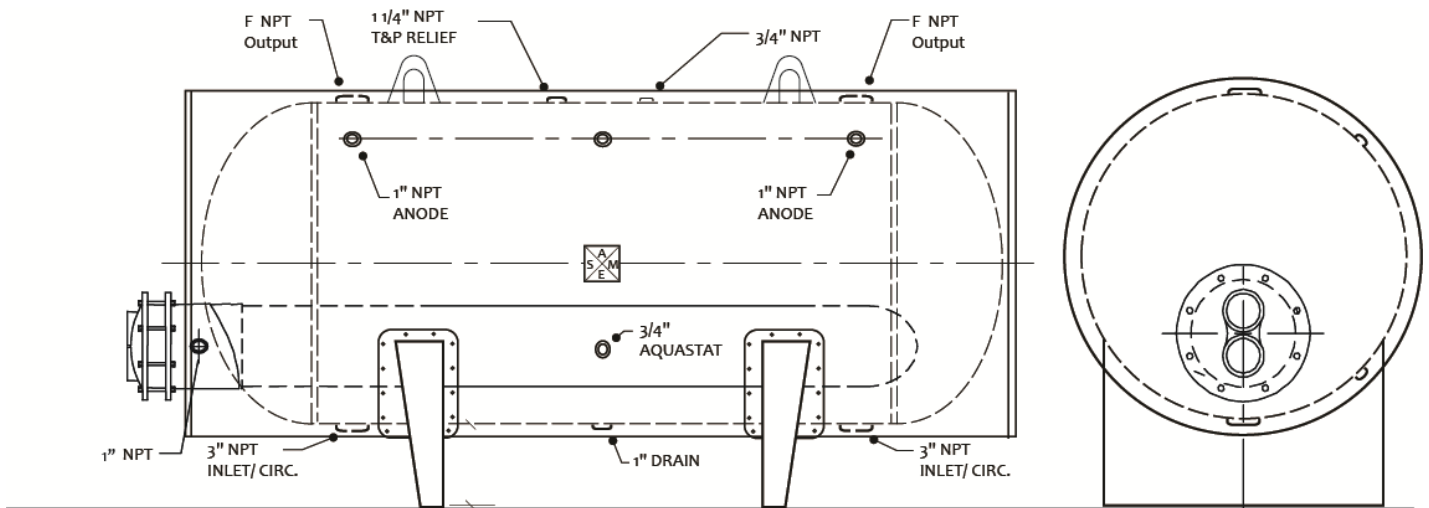

Figure 2 Horizontal Tanks



Optional Control Packages:

Steam to Water – Controls include an isolation valve, 2-way self-operated temperature regulator, inlet and outlet wye strainers, a float and thermostatic steam trap and all necessary piping.

Water to Water – Control packages include isolation valves, 2-way self-operated temperature regulator, inlet wye strainer and all necessary piping.

Options:

- Electrical control valve w/ digital controller
- Manual reset High Limit
- Manway (see notes on manway)
- Temperature & pressure Gauge
- Solenoid Valve
- 150 psi Working Pressure
- Vacuum Breaker

Figure 3 Steam to Water Operational Control Package

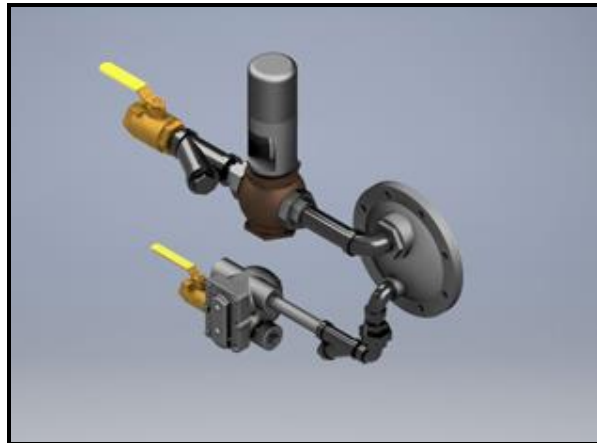
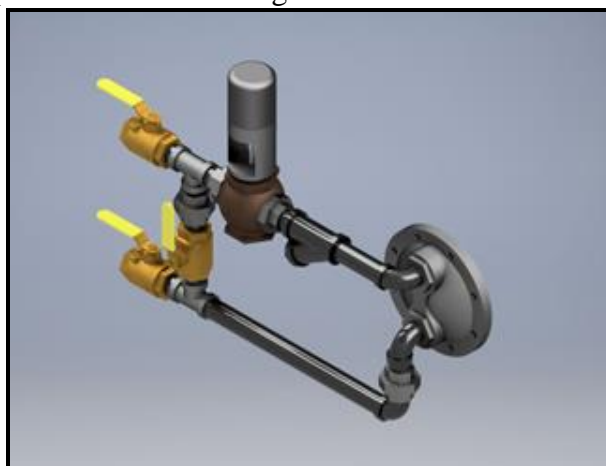

Figure 4 Water to Water Optional Control Package



WARNING

As with any piece of equipment that utilizes steam or boiler water under pressure, as well as electricity, the potential exists for severe personal injury if proper installation, operation and maintenance procedures are not followed. In addition, throughout this manual, warnings are restated when procedures are described pertaining to areas of potential danger. All warnings should be carefully read and understood. All precautions contained in the warnings should be carefully followed to reduce the chance of injury.

WARNING**Areas of potential danger**

1. All steam/ boiler water lines, joints, valves and pressure regulators
2. All hot water outlet lines, joints, valves and pressure regulators
3. All power connections and cables.

Before attempting any installation, operation or maintenance procedures pertaining to this unit:

1. Assure that the incoming steam (or boiler water) has been turned off at the manual shutoff valve.
2. If the unit has been in operation, allow the water in the heater and all components and surfaces (incoming steam line, hot water outlet, etc.) to cool before starting the procedure.
3. Assure that all power has been shut off and disconnected before attempting and procedure.
4. Assure that all incoming and outgoing water lines have been turned off at the manual shut-off valves.

WARNING

Steam or boiler water present situations that can be very dangerous due to the fact that that are under pressure and at very high temperatures. To avoid possible injury or death, use common sense and follow all accepted and recommended procedures when performing installation, operation and maintenance procedures.

WARNING

The combination of electricity and water can pose a very dangerous situation. Assure that all power has been shut off and disconnected before attempting any installation or maintenance procedures.

INSTALLATION

Transporting and unpacking the unit

In order to prevent damage during shipment the controls package is disassembled at the factory after leak testing. Reassembly will require re-attaching the unions (or bolting flange) to the appropriate locations and insertion of the control valve bulb into the provided bulbwell and the system is ready for operation (see fig.'s 5&5).

All hardware for the reassembly is included with the system. Drawings of specific controls package are included with each product illustrating the finished assembly./ For water to water systems the bypass piping union may remain attached for shipment. See Fig.'s 5 & 6. For a detailed explanation of the break points.

FIGURE 5 Steam to Water Storage Heater

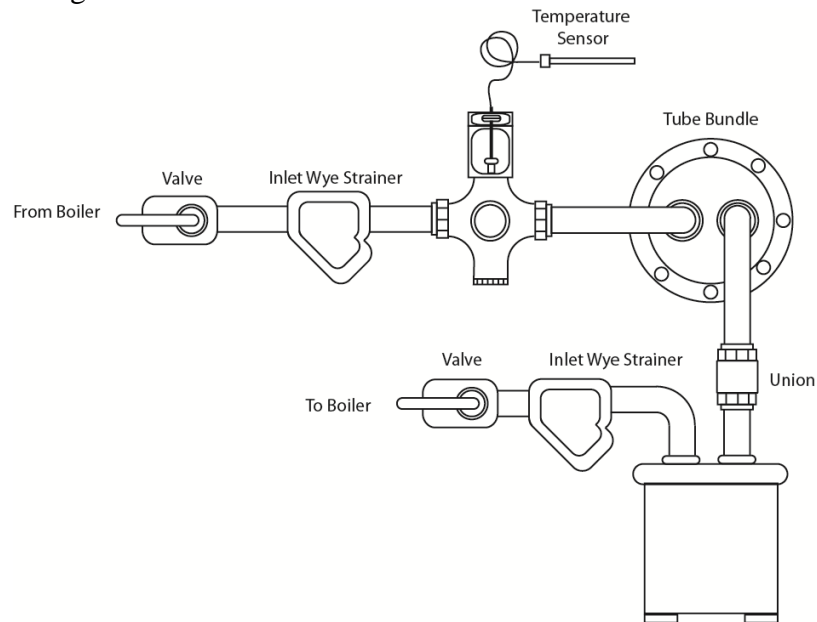
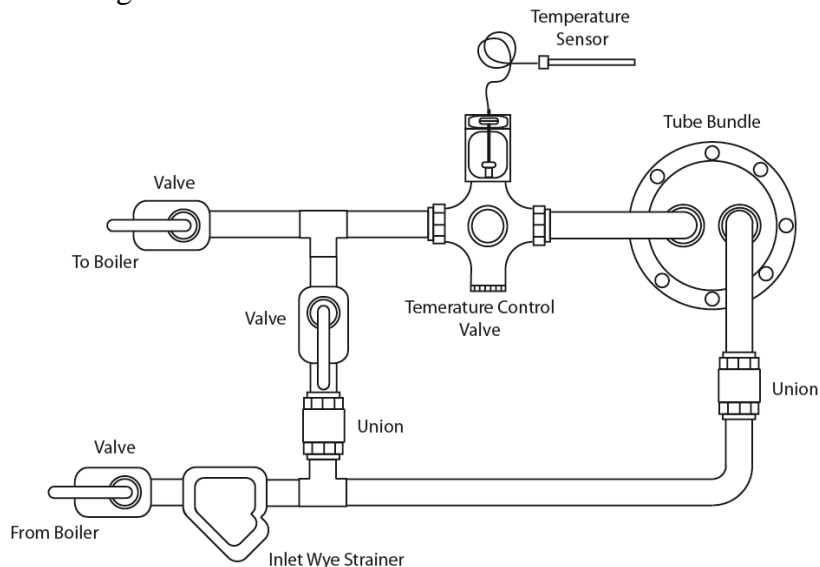

FIGURE 6 Water to Water Storage Heater



Unit and Components:

Niles Steel Tank's Hot Water Generators are designed to make installation a relatively simple procedure. Because the unit is "Packaged", after placing and mounting the unit, installation involves the following:

1. Connecting the cold water source to the water inlet
2. Connecting the hot water outlet to the hot water feed line
3. Installing the control valve bulb into the tank bulbwell.
4. Connecting the condensate / water return line and piping it to the recycling system.
5. Piping the pressure relief valve to an acceptable drain.
6. Connecting the energy source (steam or boiler water) to the unit.
7. Wiring the applicable source of electricity (if the unit is packaged with a circulating pump or electrically activated pressure or temperature controls)

Each unit is supplied with drawings that indicate the location of each connection that must be made.

Connecting the cold Water Source and the Hot Water Outlet:

NOTICE

Before making any connections of water inlet or outlet to the unit, assure they all piping is clean and free of foreign material or scale. This can usually be accomplished by "blowing out" the pipe. Any foreign material or scale entering the unit can adversely affect operation and performance.

Cold Water Source:

The first step in the installation process is to connect the cold water source to the water inlet port.

A manual shutoff valve should be installed up-stream on the cold water source as an isolation device. The shutoff valve should be in the closed position and remain so until the installation is complete.

NOTICE

For ALL piping connections, the use and / or type of joint compound or sealer on the joint should be determined by referring to local codes, accepted practices or the requirement of the installing contractor.

If the cold water source is equipped with an in-line check valve or backflow preventer, a suitable expansion tank **MUST** be installed.

Hot Water Outlet:

The next step in the installation process is to connect the hot water system piping to the hot water outlet port.

A manual shutoff valve should be installed downstream on the hot water outlet line as an isolation device in case the unit must be disconnected from the system. The shutoff valve should be in the closed position and remain so until the installation is complete.

Connecting the energy Source (steam or boiler water):

WARNING

Steam or boiler water present situations that can be very dangerous because of the high temperatures and pressures. Use common sense and follow all accepted and recommended procedures when performing installation, operation and maintenance procedures to avoid possible injury or death.

Assure that a manual shutoff valve is installed upstream in the steam or boiler water line (energy source). Its functioning properly.

Connect the energy source to the line(s) leading to the temperature control valve. The exact location of the temperature control valve for the specific unit can be determined from the drawings supplied with the unit.

NOTICE

For all energy source piping connections, the use and/ or type of joint compound or sealer on the joint should be determined by referring to local codes, accepted practices or the requirement of the installing contractor.

Connecting the Steam Condensate line or the Boiler Water Return Lines:

Steam Condensate return line

As the heat is extracted from the steam and transferred to the water heating system, condensate will form. This condensate must have a means by which it can drain from the unit and return to the steam system. The condensate return line serves this purpose.

The condensate return line should be connected to the unit at the condensate return port. The condensate port is normally located downstream from the main and auxiliary traps. The exact location of this port for the specific unit, as well as the condensate return pipe diameter, thread size and be determined from the drawings supplied with the unit. The condensate line should be piped back into the site's steam system for recycling.

WARNING

Do not attempt to lift condensate with a float and thermostatic trap. Pipe the condensate outlet from the main steam trap to a gravity drain or to a condensate pump.

Lifting condensate without the assistance of a condensate pump can cause erratic temperature control, failure of the tube bundle, damage to the control valve or damage to the condensate trap. Any failure caused due to lifting of condensate without a condensate pump is not covered by the warranty.

Boiler Water and High Temperature Water Return Line:

After the boiler water has passed through the tube bundle, and the heat has been transferred to the domestic water system, the water must return to the system. The water return lines serves this purpose.

The water return line should be connected to the unit at the return port. Unlike the steam condensate return line, the return lines for boiler water do not have in-line condensate traps. The exact location of this port for the specific unit, as well as the water return pipe diameter and thread size can be determined from the drawings supplied with this unit.

Piping the Relief Valves to Drain:

All Niles Steel Tank's Hot Water Generators are equipped with a pressure relief valve opening. Relief valves should be piped to a vent line leading to a suitable drain. Piping the pressure relief valves to suitable drains will prevent both water and heat damage to the unit, as well as reduce the risk of injury from released steam or hot water. The pipe must be of adequate size to properly handle the capacity of the relief valve and vent line. Check local codes to assure compliance.

WARNING Do not install a valve between the water heater relief valve and the vent. Doing so could cause serious injury or death if the pressure relief valve released and the manual valve was closed. This would cause excessive buildup of pressure in the water heater which could result in an explosion.

Connecting the Circulation Pump and Electrically Activated Controls:

Niles Steel Tank offers an optional circulation pump package for all Hot Water Generators. If the unit being installed is so equipped, the correct power source must be connected. The circulation pump must run all the time. Wire this pump to a correctly sized disconnect switch per local codes.

WARNING The combination of electricity and water can pose a very dangerous situation. Assure that all electric power has been turned off before attempting any installation or maintenance procedures.

Reference the wiring drawing included with the unit or the installation instructions contained in the installation manual for the component, for specific wiring instructions.

NOTICE All power connections should be performed by trained, certified electricians.

Completing Installation:

Installation of the Niles Steel Tank Hot Water Generator is now complete. All documentation supplied with the unit should be passed along to the maintenance personnel for future reference.

OPERATION:

After all installation procedures have been completed, and all water, energy source joints, and power connections have been double checked, the unit is ready for operation. As a precaution, it is strongly suggested that the following Startup and Shutdown procedures be followed.

Startup procedure:

1. Assure that all manual shutoff valves on the water and energy source lines are closed.
2. Slowly open the manual shutoff valve on the cold water inlet line, checking to assure that there are no leaks at the valve or any joints. Allow the tank to fill with water. As the tank is filling, hold the pressure relief valve open to allow air to bleed out of the tank. This will speed the filling process.
3. Adjust the operating temperature control to the desired operating temperature.
4. Set the high temperature limit thermostat at 10 to 15 degrees Fahrenheit above the desired operating temperature.
5. If the unit is so equipped, turn on the internal circulating pump. The circulating pump will operate constantly as long as power is supplied to the pump. Shutoff valves are located on the inlet and/or outlet side of the circulating pump line. These valves should be opened before the pump is turned on. After the power to the pump is turned on verify that the pump is working.
6. Open the valve on the condensate drain line, or boiler water return line.
7. For steam to water controls, slowly open the manual shutoff valve on the steam inlet. Create a load/demand situation of approximately 10 to 25% of the system design conditions. As the valves are being opened, check for leaks at the valves and all pipe joints.
8. For water to water controls, slowly open the manual shutoff valves on the boiler water inlet and outlet lines. Create a load/demand situation of approximately 10 to 25% of the system design conditions. As the valves are being opened, check for leaks at the valves and all pipe joints. Open the bypass loop ball valve approximately half way. Allow the system to push air out of the tube bundle and the piping slowly.

Note:

It should be noted that when the control valve is closed the boiler water will flow through the bypass loop. When the valve is open, less water will “bypass”. Adjustment of the bypass loop ball valve will be necessary to balance your system. For initial installation the bypass valve should be closed.

WARNING

Steam or boiler water present situations that can be very dangerous because of the high temperatures and pressures. Use common sense and follow all accepted and recommended procedures when performing installation, operations, and maintenance procedures to avoid possible injury or death.

9. Turn on power to the rest of the electrically controlled components on the unit (if equipped).
10. As the unit is initially heating the water, carefully re-inspect cold water inlet, hot water outlet, steam inlet (or boiler water inlet), and condensate return (or boiler water return line) joints for signs of leakage.
11. As the unit approaches the desired operating temperature, adjust the temperature control valve.

12. After the unit has reached operating temperature, re-inspect all joints for signs of leakage. IN addition, check all gauges and controls to verify that the water temperature and pressure, as well as energy source pressure, are within design specifications.
13. The unit in now ready for normal operation.

Shutdown procedure:

1. Turn off all power to the circulating pump and/or electric controls, if equipped.
2. Close all valves in the steam inlet line (or boiler water line).
3. Relieve the pressure from the energy source line (steam or boiler water), where possible.
4. Close all remaining valves in the system in this order:
 - the hot water outlet line;
 - the cold water inlet line; and
 - the condensate return line (or boiler water return line)
5. After the system has cooled, drain the unit by opening the tank drain valve and holding the pressure relief valve in the open position. The will prevent the formation of a vacuum and increase the drainage flow.
6. Proceed with the required maintenance or repairs.
7. After performing the required maintenance or repairs, return the unit to operation by following the Startup Procedure.

INSPECTION:

The following table summarizes the recommended time intervals for inspections of the water heater, components, inlet and outlet water, energy source lines (steam or boiler water), and power connections.
Table Here

Recommended Inspections						
To Be Inspected	Time Interval					
	Per Manufacturer Specifications	Weekly	Monthly	Quarterly	Semi Quarterly	Annually
Circulating Pump	X					
Control Valves – Temperature & Pressure	X					
Gauges – Pressure & Temperature				X		
Lines – Inlet, Outlet & Return				X		
Power Connections				X		
Pressure Relief Valve	X					
Shutoff Valves - Manual		X				
Single Solenoid Safety System					X	
Strainers				X		
Temperature – Water & Operating				X		
Thermometer			X			
Traps – Main & Auxiliary						X
Magnesium Anode Rods				X		

TROUBLESHOOTING:

SYMPTOM Water heater does not maintain the required temperature at the rated capacity.

PROBABLE CAUSE:

1. The thermometer is not correctly sensing the water temperature
2. Inlet energy source pressure is too low or boiler water temperature is too low
3. The condensate / water return piping has not been installed properly allowing the condensate / water to drain freely (by gravity); the condensate / water drain line is restricted; or the condensate / water check valve is leaking or has failed.
4. Water bypass valve has not been adjusted (boiler water).
5. Control valve bulb not installed or not property installed in tank bulbwell.
6. Control valve actuator defective.

CORRECTIVE ACTION

1. Check the water temperature with a temperature gauge that is known to be correct. Replace the thermometer if it is found to be incorrectly sensing the water temperature
2. Check the primary energy source pressure/temperature. If the reading is low, adjust the inlet pressure/temperature to meet the design requirement. If there is a restriction in the primary energy source line, the pressure reading will drop excessively when the generator calls for full energy on steam systems, even though the pressure seems to be normal during light demand. If the primary pressure is correct, the systems should reach design pressure for energy source in the tube bundle as the temperature of the water in the tank heater approaches shutoff.
3. Reconfigure the condensate / water return piping and check valve to allow for proper drainage. Check to assure that there is no restriction in the condensate / water drain line. Replace the check valve if it is leaking or has failed. Also, check to assure that there is no restriction in the condensate / water drain line.
4. Adjust bypass valve approximately half closed. Notify factory for replacement
5. Verify actuator is not working. Notify factory for replacement.

SYMPTOM Outlet temperature is too high.

PROBABLE CAUSE

1. The thermometer is not correctly sensing the water temperature.
2. The condensate / water return piping has not been installed properly, allowing the condensate / water to drain freely (by gravity); the condensate / water drain line is restricted; or the condensate / water check valve is leaking or has failed.
3. Control valve bulb not installed or not properly installed in tank bulbwell.
4. Control valve actuator defective.

CORRECTIVE ACTION

1. Check the water temperature with a temperature gauge that is known to be correct. Replace the thermometer if it is found to be incorrectly sensing the water temperature.
2. Reconfigure the condensate / water return piping and check valve to allow for proper drainage. Check to assure that there is no restriction in the condensate / water drain line. Replace the check valve if it is leaking or has failed. Also, check to assure that there is no restriction in the condensate / water drain line.
3. Verify bulb is installed in bulbwell.
4. Verify actuator is not working. Notify factory for replacement.

SYMPTOM Outlet temperature fluctuates widely.

PROBABLE CAUSE

1. Inlet energy source pressure is too low or boiler water temperature is too low.
2. The condensate / water return piping has not been installed properly, allowing the condensate / water to drain freely (by gravity); the condensate / water drain line is restricted; or the condensate / water check valve is leaking or has failed.
3. The primary / inlet temperature control valve is not closing properly.
4. Bypass valve not adjusted (boiler water)
5. The primary / inlet temperature control valve is not opening properly.

CORRECTIVE ACTION

1. For steam systems check the primary energy source pressure/temperature. If the reading is low, adjust the inlet pressure/temperature to meet the design requirements. If there is a restriction in the primary energy source line, the pressure reading will drop excessively when the generator calls for full energy on steam systems, even though the pressure seems to be normal during light demand. If the primary pressure is correct, the systems should reach design pressure for energy source in the tube bundle as the temperature of the water in the tank heater approaches shutoff.
2. Reconfigure the condensate / water return piping and check valve to allow for proper drainage. Check to assure that there is no restriction in the condensate / water drain line. Replace the check valve if it is leaking or has failed. Also, check to assure that there is no restriction in the condensate / water drain line.
3. Verify control valve bulb was installed in the bulbwell.
4. Adjust bypass valve approximately half closed. Readjust as necessary.
5. Verify control valve actuator is working properly, if not replace.

SYMPTOM Excess or insufficient condensate (boiler water) being returned from the unit.

PROBABLE CAUSE

1. The condensate / water return piping has not been installed properly, allowing the condensate / water to drain freely (by gravity); the condensate / water drain line is restricted; or the condensate / water check valve is leaking or has failed.
2. Bypass loop valve not adjusted (boiler water).

CORRECTIVE ACTION

1. Reconfigure the condensate / water return piping and check valve to allow for proper drainage. Check to assure that there is no restriction in the condensate / water drain line. Replace the check valve if it leaking or has failed. Also, check to assure that there is no restriction in the condensate / water drain line.
2. Adjust bypass valve approximately half closed. Readjust as necessary.

SYMPTOM Steam being discharged into the condensate drain.

PROBABLE CAUSE

1. The tube bundle is heavily scaled or damaged.

CORRECTIVE ACTION

1. Call Niles Steel Tank, or an authorized sales agent for instruction on repair or replacement.

SYMPTOM Pressure relief valve “pops”.

PROBABLE CAUSE

1. The primary / inlet temperature control valve is not closing properly.
2. The secondary / outlet energy source pressure control system is not operating properly.
3. The over-temperature limit system is out of adjustment, or some component of the system has failed.

CORRECTIVE ACTION

1. Verify control valve bulb was installed in tank bulbwell.
2. Verify control valve actuator is operating properly.
3. Check the individual components of the systems and repair or replace the failed component(s) as necessary.

SYMPTOM Water shuts down at or too close to (above or below) the design outlet temperature.

PROBABLE CAUSE

1. The over-temperature limit system is out of adjustment, or some component of the system has failed.

CORRECTIVE ACTION

1. Check the individual components of the system and repair or replace the failed component(s) as necessary.

SYMPTOM A loud banging in the water heater, primary piping, or condensate water return piping (not to be confused with a normal clicking noise made during operation).

PROBABLE CAUSE

1. The condensate / water return piping has not been installed properly, allowing the condensate / water to drain freely (by gravity); the condensate / water drain line is restricted; or the condensate / water check valve is leaking or has failed.
2. Primary / inlet steam line is not properly trapped (steam as energy source only).

CORRECTIVE ACTION

1. Reconfigure the condensate / water return piping and check valve to allow for proper drainage. Check to assure that there is no restriction in the condensate / water drain line. Replace the check valve if it is leaking or has failed. Also, check to assure that there is no restriction in the condensate / water drain line.
2. The steam supply should be clean dry steam. Do not slug controls system with boiler startup condensate. This can damage controls as well as tube bundle.

MAINTENANCE:

Storage Tank Maintenance:

A new tank installation should have a regular inspection program set up. The first inspection should be within the first three months of operation. Once the tendency to accumulate sediment has been established, the inspection program can be modified to suit the water conditions. Typical inspection programs flush the tank at six-month intervals and clean the tank in yearly intervals.

De-liming solvents or acid type flush agents are not recommended for use in lined storage tanks. These chemical cleaners are usually designed for use in non-potable systems such as heating boilers. These chemicals may be aggressive and cause damage to the tank lining and deteriorate the magnesium anodes supplied in glass-lined storage tanks.

WARNING

Hot water will be released under pressure. Avoid contact with the hot discharge water to prevent the risk of severe scald injury.

Flushing the Storage Tank:

Since the mineral accumulation is occurring in an un-fired tank it will be in soft sediment form. This soft sediment can be removed by a regular flushing of the lower portion of the tank.

To flush the tank, follow these steps:

1. Turn off electrical power to the circulating pump and any other tank accessories.
2. Close the valve on the hot water outlet on the top of the storage tank.
3. Ensure that the drain located on the bottom of the tank is routed to a floor drain with adequate capacity to allow the tank to be flushed.
4. Open the drain valve and allow the incoming cold water to flush the soft sediment out the bottom of the storage tank. Use extreme caution, as the water exiting the tank drain may be very hot. Avoid contact with the hot discharge water to prevent the risk of severe scald injury.

5. Observe the color of the water in initially discharged from the tank drain. This water will generally be milky or slightly discolored by the sediment discharge. Allow the drain to run until the water runs clear.
6. Close the drain valve on the tank.
7. Open the hot water outlet valve on the top of the tank.
8. Open an adjacent hot water tap to purge any air that may have entered the storage tank during the draining process. Close the hot water tap if no discharge is observed.
9. Turn on electric power to the circulating pump and other electrical components if necessary.
10. Observe tank and piping to ensure all components are functioning properly.

Cleaning the Storage Tank:

The mineral accumulation in an un-fired tank will be in a soft sediment form that can be removed by a regular cleaning of the lower portion of the tank. Many tanks will have a hand hole or a larger manway to allow access to the interior of the tank for complete removal of accumulated sediment. An access opening to remove the manway or hand hole is provided in the exterior jacket. The sheetmetal jacket components are removed with hand tools. The opening will be in the bottom portion of a vertical tank and on the end of a horizontal tank (see FIG's 1 and 2 on page 4 of this manual).

NOTICE It is important to never re-use a manway or hand hole gasket. Obtain a new manway or hand hole gasket before any procedure.

To clean the tank, follow these steps (reference FIG.'s 7 and 8):

1. Close valves from boiler water steam supply and return or condensate pipes.
2. Turn off electrical power to the circulating pump and other electrical components if necessary.
3. Close the valve on the hot water outlet on the top of the storage tanks and the cold water supply to the system.
4. Ensure that the drain located on the bottom of the tank is routed to a floor drain with adequate capacity to allow the tank to be drained.
5. Open the drain valve and open a vent to allow the air to enter the tank (manually opening the relief valve will usually accomplish this). Use extreme caution, as the water exiting the tank drain may be very hot. Avoid contact with the hot discharge water to prevent the risk of severe scald injury.
6. Allow the tank to drain completely.
7. Remove the jacket cover over the manway or hand hole. Remove the bolt(s) securing the tank access opening. Use a flashlight to observe the sediment collected in the tank.
8. Use hand tools to remove all sediment from the interior of the tank. Use care not to damage the interior lining of the storage tank.
9. Use a water hose to flush the remaining sediment from the interior surfaces of the tank and ensure that all debris is removed. Scale or sediment allowed to reach the potable system can foul valves, pumps, strainers, and other water fixtures. Ensure that the tank interior is clean before refilling the vessel.
10. Install a new gasket on the manway or hand hole to prevent any possible leaks. Tighten the gasket properly to prevent leaks.

CAUTION Over tightening the gasket can result in cutting the gasket and allowing a water leak to occur.

11. Replace the jacket cover over the manway or hand hole.
12. Close the drain and open the cold water supply and hot water outlet. If the relief valve was used for a vent ensure that it is now closed. Open the closest hot water valve to allow the air in the tank to vent as water enters the vessel. Close the valve opened for a vent when water flows from the valve.
13. Check the manway or hand hole and all related piping for any water leaks.
14. Turn on electric power to the circulating pump and other electric components if necessary.
15. Open the valves for boiler water or steam supply. Also open the boiler water return, or condensate line.
16. Observe tank and piping to ensure all components are functioning properly.

Magnesium Anode Rod Inspection:

Glass lined storage tanks have a magnesium anode(s) to provide cathodic protection of the lining and minimize corrosion. Aggressive water condition in some areas of the county may accelerate the deterioration of the anode(s). The anode(s) should be periodically removed and inspected to determine if replacement is necessary.

The tank must be valved off from the system and fully drained to remove an anode for inspection. Anodes are supplied in threaded fittings on the top head of small vertical storage tanks. Top mounted anodes may be accessed by removing the jacket top. Large vertical storage tanks and horizontal tanks have multiple anodes installed in threaded tapping along the length of the tank. These anodes may be accessed by removing a jacket panel and/or corner post corresponding to the mounting point of the anodes. Adequate service clearance is required to allow removal of an anode. The anode(s) should be replaced when more than six inches of the core wire is exposed at either end of the rod. Medium sized tanks with round jackets provide an opening for individual anode rod access.

Figure 7_Horizontal Storage Tank w/Anodes

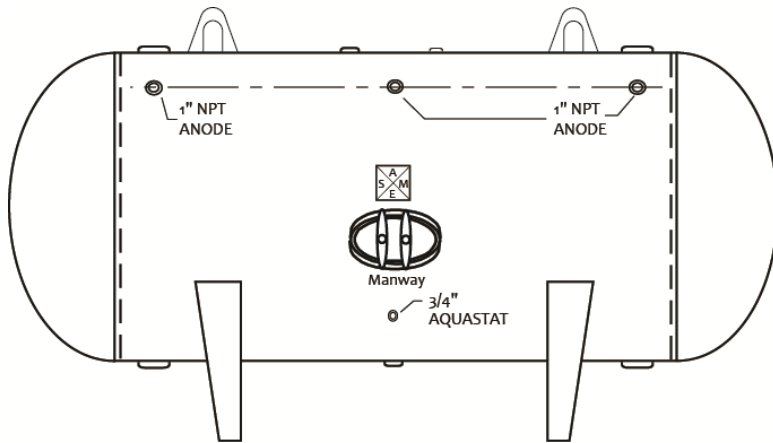
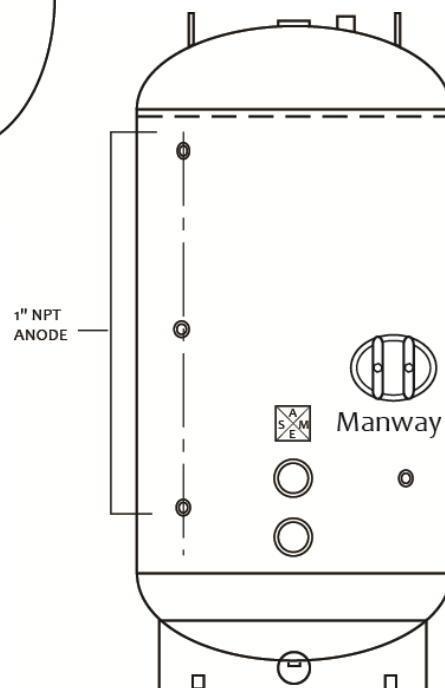

Figure 8_Vertical Storage Tank w/Anodes



Component(s) Replacement:

Circulating Pump – Inspection and Replacement:

Niles Steel Tank Hot Water Generators can be equipped with a circulating pump to assist in the even heating of the water. If the unit is equipped with a circulating pump, the following procedure should be followed to replace the pump.

1. Follow Steps 1 through 5 of the shutdown procedure (page 10) to take the unit off-line before attempting to service the circulating pump.

WARNING The combination of electricity and water can pose a very dangerous situation. Turn off / disconnect all electric power before attempting any maintenance procedure.

2. Refer to the manufacturer's documentation supplied with the unit pertaining to testing the pump. If found to be defective or questionable, replace the pump by continuing with the steps that follow.
3. After assuring that the power has been turned off, disconnect the electric lead, to the circulating pump (FIG. 9).
4. Close the manual shutoff valves located near the inlet and outlet ports of the pump.

WARNING Hot water may be present in piping.

5. Break the joints between the pump and the inlet and outlet piping. Remove the pump.
6. Reconnect the pump to the inlet and outlet piping. Follow recommendations contained in the manufacturer's documentation, local codes, or accepted contractor practices as to the use and / or type of joint compound or sealer at the connections.
7. Open the manual shutoff valves located on the inlet and outlet sides of the pump and check for any leakage at the joints.
8. Reconnect the electric leads to the pump (reference FIG. 9 to assure proper wiring).
9. Follow the startup procedures (page 10) to put the unit back on-line. Carefully check all connections for any sign of leakage.

Circulating Pump Shutoff Valves – Replacement:

If the Niles Steel Tank is equipped with a circulating pump, manual shutoff valves will be located on both the inlet and outlet side piping. To replace the valves, follow the procedure detailed below.

1. Follow Steps 1 through 5 of the shutdown procedure (page 10) to take the unit off-line before attempting to service the circulating pump shutoff valves.

WARNING The combination of electricity and water can pose a very dangerous situation. Turn off / disconnect all electric power before attempting any maintenance procedure.

2. After assuring that the power has been turned off, disconnect the electric leads to the circulating pump (FIG. 9).
3. Break the joints between the pump and the inlet and outlet piping. Remove the pump.

4. Remove the shutoff valves.
5. Install the new valves. Follow recommendations contained in the manufacturer's documentation, local codes, or accepted contractor practices as to the use and / or type of joint compound, sealer, solder or flux at the connections.
6. Reconnect the pump to the inlet and outlet piping. Follow recommendations contained in the manufacturer's documentation, local codes, or accepted contractor practices as to the use and / or type of joint compound or sealer at the connections
7. Open the manual shutoff valves located on the inlet and outlet sides of the pump.
8. Reconnect the electric leads to the pump (reference FIG. 9 to assure proper wiring).
9. Follow the startup procedures (page 10) to put the unit back on-line. Carefully check all joints for any sign of leakage.

Figure 9_ Pump Wiring Diagram

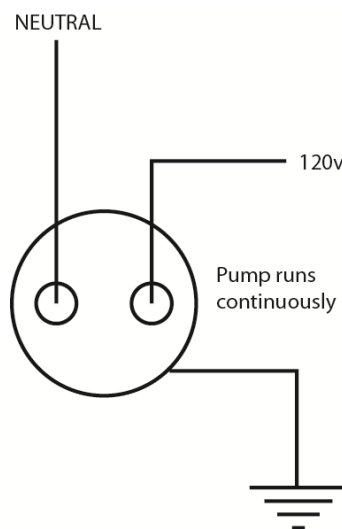

Power Connections – Rewiring:

If any of the power connections must be rewired at the circulating pump or electrically activated controls, follow the steps listed below.

WARNING The combination of electricity and water can pose a very dangerous situation. Turn off / disconnect all electric power before attempting any maintenance procedure.

1. Follow Steps 1 through 4 of the shutdown procedure (page 10) to take the unit off-line before attempting any electrical service.
2. After assuring the power has been turned off, disconnect and rewire the electrical connections in question.
3. Turn the power on and check that the component that has been rewired is functioning properly.
4. Slowly open the shutoff valves on the condensate (or boiler water return) line, cold water inlet line, and hot water outlet line.
5. Slowly open the shutoff valves on the energy source inlet line.

Tube Bundle – Inspection and Replacement:

The tube bundle is the heart of the Niles Steel Tank Water Generator. It should be removed and inspected every two (2) years. Before removing, be sure you have the necessary replacement gaskets.

WARNING

Steam or boiler water present situations that can be very dangerous because of the high temperatures and pressures. To avoid possible injury or death, use common sense and follow all accepted and recommended procedures when performing installation, operation, and maintenance procedures.

WARNING

The combination of electricity and water can pose a very dangerous situation. Turn off / disconnect all electric power before attempting any maintenance procedure.

1. Follow Steps 1 through 5 of the shutdown procedure (page 10) to take the unit off-line before attempting to remove and inspect the tube bundle.
2. Assure that the energy source, condensate / water return line, cold water inlet, and hot water inlet have been shut off; that the tank has been completely drained; that the pressure line has been bled from both the water and energy source systems; and that the water, all components, and surfaces have cooled.
3. Carefully break the connections between the tube bundle head and the energy source inlet and outlet lines.

WARNING

It may be necessary to break the lines at a second location, and for the lines to be rotated to allow clearance for the tube bundle to be removed from the tank. If it is necessary, care should be taken to ensure that in-line components are not damaged.

4. Break the bolts loose that secure the tube bundle head to the tank. After all bolts have been broken loose, remove them from the unit.

WARNING

The tube bundle head is heavy and can cause serious injury if it falls on your foot, leg, etc., use caution

WARNING

The tube bundle weight depends on the size installed. A hoist or some type of lift system should be made available to assist in removal or installation of the tube bundle.

5. Remove the tube bundle from the tank, use care not to damage the soft copper tubes.
6. Inspect for damage or excessive scale, etc.
7. Remove old gaskets and clean gasket sealing surfaces.
8. Reinstall the tube bundle.

Inlet, Outlet, and Condensate/ Water Return Line and Manual Shutoff Valves – Replacement:

If any of the inlet, outlet, return lines, or shutoff valves are damaged and must be replaced, follow the steps outlined below.

WARNING

The combination of electricity and water can pose a very dangerous situation. Turn off / disconnect all electric power before attempting any maintenance procedure.

1. Follow Steps 1 through 5 of the shutdown procedure (page 10) to take the unit off-line before attempting to replace damaged lines or shutoff valves.

WARNING

While it may seem feasible to replace inlet, outlet, condensate / water return lines, and shutoff valves without shutting down the entire unit, it is not advised. Unless the unit is completely shutdown, and the water and the energy source are isolated from the system, failure of a manual shutoff valve during the replacement process could result in serious injury.

2. Assure that the energy source, condensate / water return line, cold water inlet, and hot water outlet have been shut off; that the tank has been completely drained; that the pressure has been bled from both the water and energy source systems; and that all components and surfaces have cooled.
3. Carefully break the joint between the unit and the line or valve to be replaced.
4. Remove the section of line or valve to be replaced.
5. Replace the damaged section of line or valve.
6. Reconnect the line or valve to the unit. Follow recommendations contained in the manufacturer's documentation, local codes, or accepted contractor practices as to the use and / or type of joint compound or sealer at the connections.
7. Follow the startup procedures (page 10) to put the unit back on-line. Carefully check all connections for any sign of leakage.

Temperature/Pressure Gauge (Tank) (Optional) – Replacement:

If the temperature/pressure gauge for the water tank is not functioning correctly and must be replaced, follow the procedure outlined below.

WARNING

The combination of electricity and water can pose a very dangerous situation. Turn off / disconnect all electric power before attempting any maintenance procedure.

1. Follow Steps 1 through 5 of the shutdown procedure (page 10) to take the unit off-line before attempting to replace the water temperature/pressure gauge.
2. Carefully unscrew the water temperature/pressure gauge from the port in the tank.
3. Install the new gauge by screwing it into the port in the tank. Follow recommendations contained in the manufacturer's documentation, local codes, or accepted contractor practices as to the use of joint compound or sealer at the connections.
4. Follow the startup procedure (page 10) to put the unit back on-line. Carefully check all connections for any sign of leakage.

Single Solenoid Safety System (Option) – Inspection and Replacement:

The single solenoid safety system closed the steam (or boiler water) control valve in an over-temperature condition. The system should be checked semi-annually. (See manufacturer's documentation for the solenoid safety system provided with the unit for specific inspection intervals and test routine.) If the system is found to be malfunctioning and must be replaced, follow the procedure outlined below.

WARNING The combination of electricity and water can pose a very dangerous situation. Turn off / disconnect all electric power before attempting any maintenance procedure.

1. Follow Steps 1 through 5 of the shutdown procedure (page 10) to take the unit off-line before attempting to replace the single solenoid safety system
2. If the system is electrically activated, turn off the power and disconnect the electric leads from the safety system.
3. Remove the solenoid valve from the piping or high limit thermostat from mounting.
4. Mount the new safety system.
5. Reference the manufacturer's documentation for the safety system that was supplied with your unit for additional installation / setup instructions.
6. Follow the startup procedures (page 10) to put the unit back on-line. Carefully check all connections for any sign of leakage.

Temperature Control Valve (Optional) – Inspection and Replacement:

The temperature control valve is installed adjacent to the rube bundle. The manufacturer's documentation included with the unit gives specifics for operation and maintenance of the control valve. The CAD drawing included with the unit will give the exact location, as well as interlocks with other components. This information should be reviewed before removal / replacement of the temperature control valve.

WARNING Steam or boiler water present situations that can be very dangerous because of the high temperatures and pressures. Use common sense and follow all accepted and recommended procedures when performing installation, operation, and maintenance procedures to avoid possible injury or death.

WARNING The combination of electricity and water can pose a very dangerous situation. Turn off / disconnect all electric power before attempting any maintenance procedure.

1. Follow Steps 1 through 5 of the shutdown procedure (page 10) to take the unit off-line before attempting to remove and inspect the temperature control valve.
2. Assure that the energy source, condensate / water return line, cold water inlet, and hot water outlet have been shut off; that the tank has been completely drained; that the pressure has been bled from both the water and energy source systems; and that all components and surfaces have cooled.
3. If the temperature control valve is electrically activated, turn off the power and disconnect the leads to the valve.
4. Remove the control valve probe from the tank port.
5. Carefully break the joints between the temperature control valve and the unions on either side of the valve per FIG.'s 5 and 6 on page 6 of this manual.
6. Carefully break the connections between the energy source inlet line and the tube bundle.

NOTICE It may be necessary to break the lines at a second location, and for the lines to be rotated to allow clearance for the temperature control valve to be removed from the systems. If it is necessary, care should be taken to ensure that in-line components are not damaged.

7. Remove the temperature control valve from the system.

8. Follow the supplied manufacturer instruction for inspecting the valve. If found to be malfunctioning, replace the valve.
9. Carefully replace the temperature control valve into the systems by reattaching it to the energy source inlet line and the tube bundle outlet line. Follow recommendations contained in the manufacturer's documentation, local codes, or accepted contractor practices as to the use and / or type of joint compound or sealer at the connections.
10. Align the valve as it was situated before removal and tighten the connections. If lines were broken at an additional location to allow for removal of the valve, be sure to also tighten those connections.
11. Reconnect the temperature control valve to the system interlocks and install the sensing probe into the tank.
12. Follow the startup procedure (page 10) to put the unit back on-line. Carefully check all connections for any sign of leakage.

Strainers – Inspection and Replacement:

The strainers are installed upstream of the energy source shutoff valve for the main traps. These strainers must be blown down periodically (approximately every three (3) to six (6) months) to prevent the build up of any sediment.

WARNING

The combination of electricity and water can pose a very dangerous situation. Turn off / disconnect all electric power before attempting any maintenance procedure.

1. Follow Steps 1 through 5 of the shutdown procedure (page 10) to take the unit off-line before attempting to replace the energy source strainers.
2. The location of the strainers can differ between packages. Reference FIG.'s 3 and 4 on page 5 of this manual to identify the location of the strainers on the unit.
3. Carefully break the line connections on the inlet side of both strainers.
4. Carefully break the line connection on the outlet side of the strainers.
5. Remove and examine the strainers.
6. Remove any sediment that is present in the strainers. If they cannot be satisfactorily cleaned, replace with new strainers.
7. Place the strainers back on-line in the system.
8. Reconnect the inlet and outlet lines to each strainer. Follow recommendations contained in the manufacturer's documentation, local codes, or accepted contractor practices as to the use and / or type of joint compound or sealer at the connections.
9. Follow the startup procedures (page 10) to put the unit back on-line. Carefully check all connections for any sign of leakage.

Traps – Replacement (Steam Systems Only):

The main and auxiliary traps are installed upstream of the condensate shutoff valve on the units that use steam as the energy source. The traps are designed to maintain the flow on condensate with the rise and fall of the float as changes in condensate level occur within the body of the trap. If the traps are not functioning properly and must be replaced, follow the procedure outlined below.

WARNING

The combination of electricity and water can pose a very dangerous situation. Turn off / disconnect all electric power before attempting any maintenance procedure.

1. Follow Steps 1 through 5 of the shutdown procedure (page 10) to take the unit off-line before attempting to replace the main or auxiliary traps.
2. The exact location of the traps can differ depending on the unit. Reference the drawing supplied with the unit to identify the location of the traps on the unit.
3. Carefully break to joint on the inlet side of the trap.
4. Carefully break the joint on the outlet side of the trap.
5. Remove and examine the trap.
6. If the trap is not functioning properly, replace it with a new trap.
7. Place the trap back on-line in the system.
8. Reconnect the inlet and outlet lines to the trap. Follow recommendations contained in the manufacturer's documentation, local codes, or accepted contractor practices as to the use and / or type of joint compound or sealer at the connection.
9. Follow the startup procedure (page 10) to put the unit back on-line. Carefully check all connections for any sign of leakage.

