



**NST**  
**NILES**  
**STEEL**  
**TANK**  
SINCE 1898

# MODEL # BH-72-216-TC

## Design Notes

Code..... ASME Sec IV HLW  
 Design Pressure..... 125 psi  
 Test Pressure..... 125 psi  
 Interior..... Ultonium Glass Lining  
 Exterior..... R-16 Topcoat Insulation  
 Supports..... Saddles  
 Capacity..... 3567 Gal. / 3805 nominal  
 Weight..... 5418 Lbs.

## Material Specifications

Heads..... Carbon Steel  
 Shell..... Carbon Steel  
 Couplings..... Carbon Steel  
 Flanges..... N/A  
 Pipe..... N/A  
 Manway..... Carbon Steel

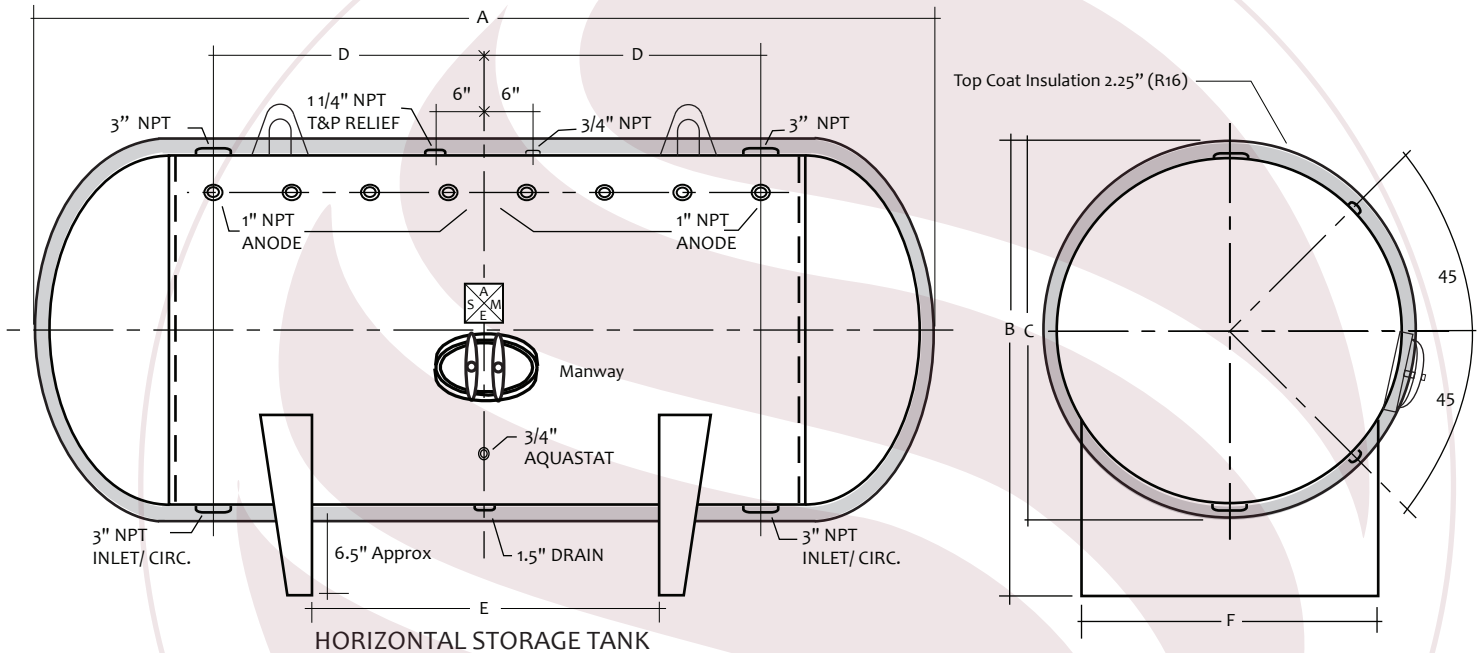

Suitable for outdoor applications

\*\* Overall height, length and diameter may vary due to variations in Topcoat thickness

Mark	Dimension	Remark	NOTES
A	221"	Overall length (Includes Topcoat)	PROJECT
B	83.25"	Overall height (Includes Topcoat)	CUSTOMER
C	77"	Diameter (Includes Topcoat)	SCALE Not to Scale
D	84"	Circulation	DATE
E	145.5"	Supports	CUSTOMER P.O. #
F	63"	Support width	DRAWING Rev NO.