



NST
NILES
STEEL
TANK
SINCE 1898

MODEL # BH-72-168-TC

Design Notes

Code..... ASME Sec IV HLW
 Design Pressure..... 125 psi
 Test Pressure..... 125 psi
 Interior..... Ultonium Glass Lining
 Exterior..... R-16 Topcoat Insulation
 Supports..... Saddles
 Capacity..... 2727 Gal. / 2959 nominal
 Weight..... 4394 Lbs.

Material Specifications

Heads..... Carbon Steel
 Shell..... Carbon Steel
 Couplings..... Carbon Steel
 Flanges..... N/A
 Pipe..... N/A
 Manway..... Carbon Steel

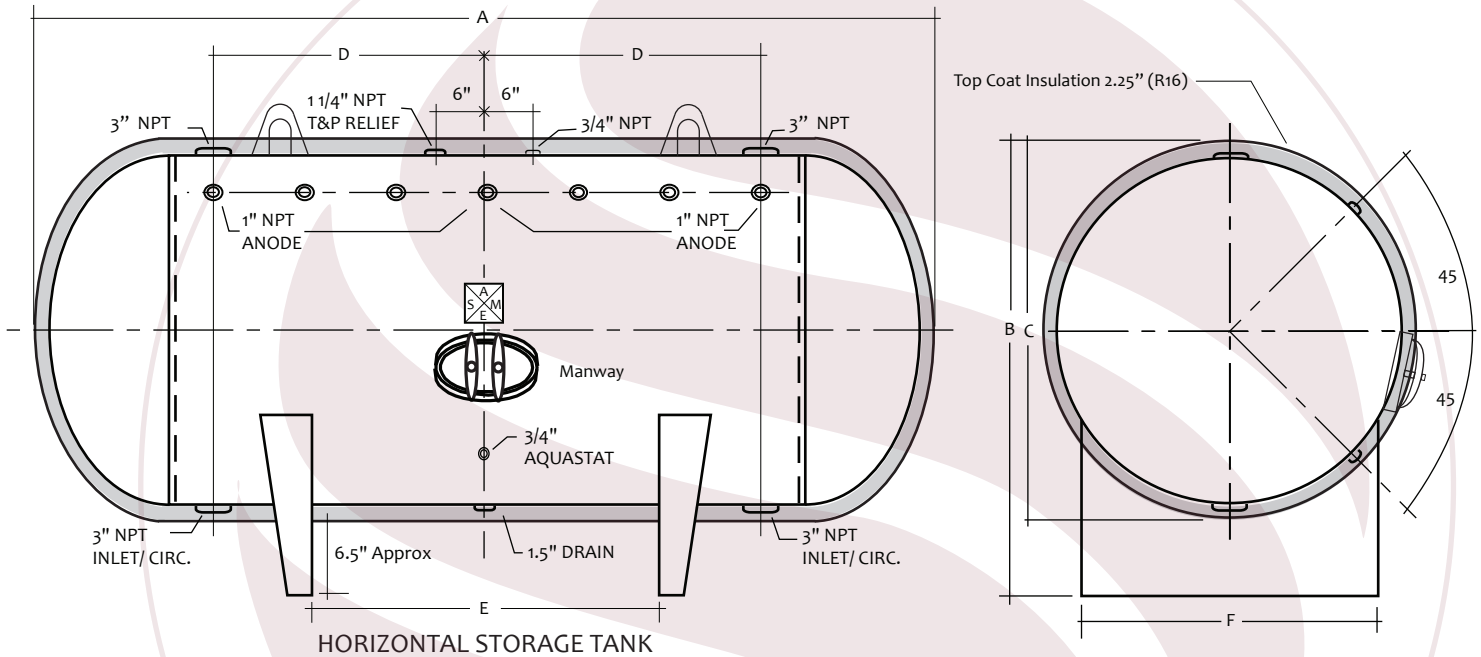

Suitable for outdoor applications

** Overall height, length and diameter may vary due to variations in Topcoat thickness

Mark	Dimension	Remark	NOTES
A	173"	Overall length (Includes Topcoat)	PROJECT
B	83.25"	Overall height (Includes Topcoat)	CUSTOMER
C	77"	Diameter (Includes Topcoat)	SCALE Not to Scale
D	60"	Circulation	DATE
E	97.5"	Supports	CUSTOMER P.O. #
F	63"	Support width	DRAWING Rev NO.