



NST
NILES
STEEL
TANK
SINCE 1898

MODEL # BH-60-210-TC

Design Notes

Code..... ASME Sec IV HLW
 Design Pressure..... 125 psi
 Test Pressure..... 125 psi
 Interior..... Ultonium Glass Lining
 Exterior..... R-16 Topcoat Insulation
 Supports..... Saddles
 Capacity..... 2395 Gal. / 2570 nominal
 Weight..... 4172 Lbs.

Material Specifications

Heads..... Carbon Steel
 Shell..... Carbon Steel
 Couplings..... Carbon Steel
 Flanges..... N/A
 Pipe..... N/A
 Manway..... Carbon Steel

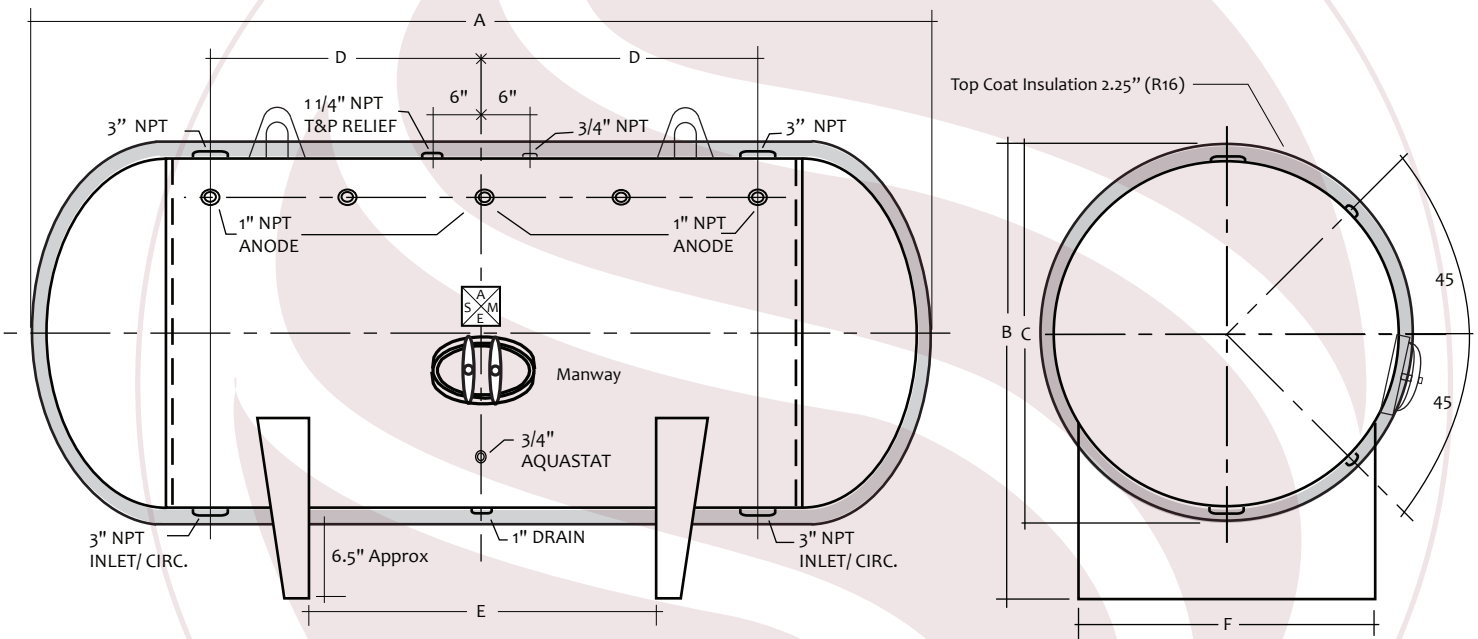

HORIZONTAL STORAGE TANK

** Overall height, length and diameter may vary due to variations in Topcoat thickness

Mark	Dimension	Remark	NOTES
A	215"	Overall length (Includes Topcoat)	PROJECT
B	71.25"	Overall height (Includes Topcoat)	CUSTOMER
C	65"	Diameter (Includes Topcoat)	SCALE Not to Scale
D	84"	Circulation	DATE
E	162"	Supports	CUSTOMER P.O. #
F	52.5"	Support width	DRAWING Rev NO.