



NST
NILES
STEEL
TANK
SINCE 1898

MODEL # BH-84-210

Design Notes

Code..... ASME Sec IV HLW
 Design Pressure..... 150 psi
 Test Pressure..... 150 psi
 Interior..... Ultonium Glass Lining
 Exterior..... R-16 topcoat insulation
 Supports..... Saddles
 Capacity..... 4610 Gal./ 5038 nominal
 Weight..... 7327 Lbs.

Material Specifications

Heads..... Carbon Steel
 Shell..... Carbon Steel
 Couplings..... Carbon Steel
 Flanges..... Carbon Steel
 Pipe..... N/A
 Manway..... Carbon Steel

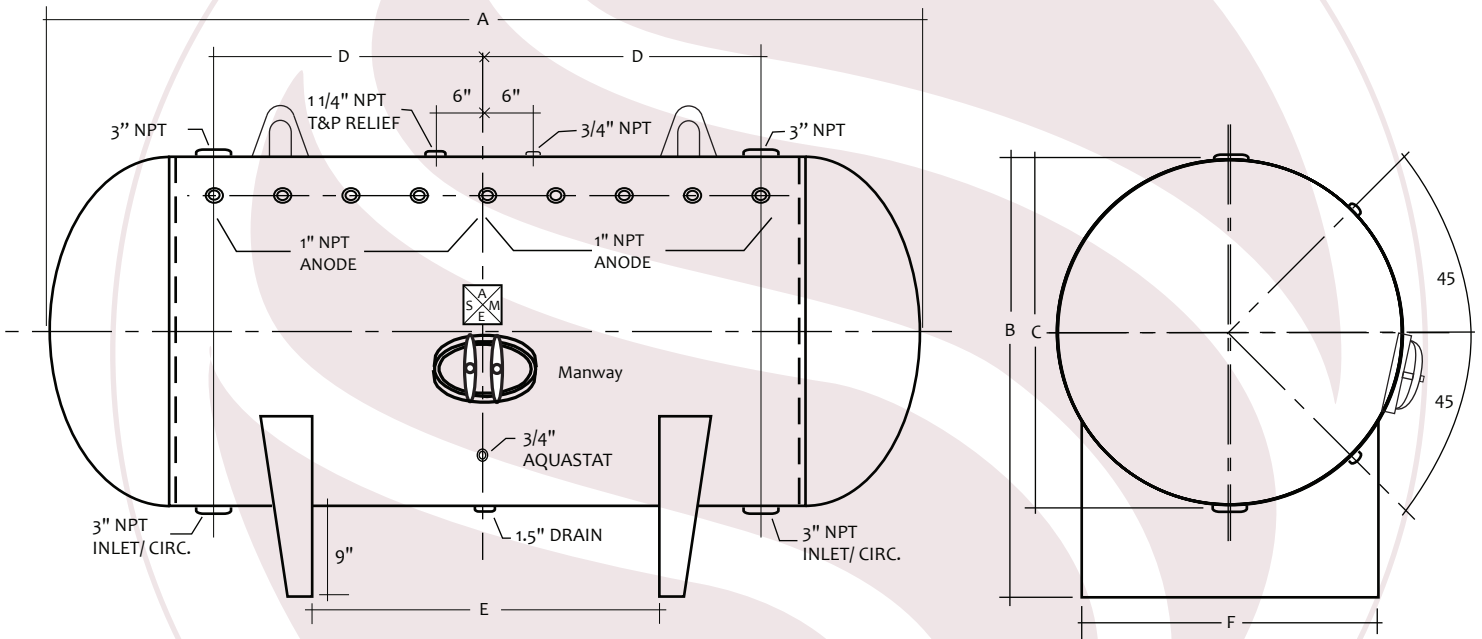

HORIZONTAL STORAGE TANK

Mark	Dimension	Remark
A	210"	Overall length
B	84"	Diameter
C	93"	Overall height
D	77"	Circulation
E	127.5"	Support width
F	73"	Support width

NOTES	
PROJECT	
CUSTOMER	
SCALE	Not to Scale
DATE	
CUSTOMER P.O. #	
DRAWING Rev NO.	