



**NST**  
**NILES**  
**STEEL**  
**TANK**  
SINCE 1898

# MODEL # S-36-114-TC

## Design Notes

Code..... ASME Sec IV HLW  
 Design Pressure..... 125 psi  
 Test Pressure..... 125 psi  
 Interior..... Ultonium Glass Lining  
 Exterior..... R-16 Topcoat Insulation  
 Supports..... Skirt  
 Capacity..... 465 Gal. / 502 nominal  
 Weight..... 818 Lbs.

## Material Specifications

Heads..... Carbon Steel  
 Shell..... Carbon Steel  
 Couplings..... Carbon Steel  
 Flanges..... N/A  
 Pipe..... N/A  
 Manway..... N/A

\*\* Overall height and diameter may vary due to variations in Topcoat thickness

Mark	Dimension	Remark
A	120.25"	Overall height (Includes Insulation)
B	114"	Tank height
C	34.5"	Diameter (Includes Insulation)
D	17.5"	Circulation

NOTES	
PROJECT	
CUSTOMER	
SCALE	Not to Scale
DATE	
CUSTOMER P.O. #	
DRAWING Rev NO.	

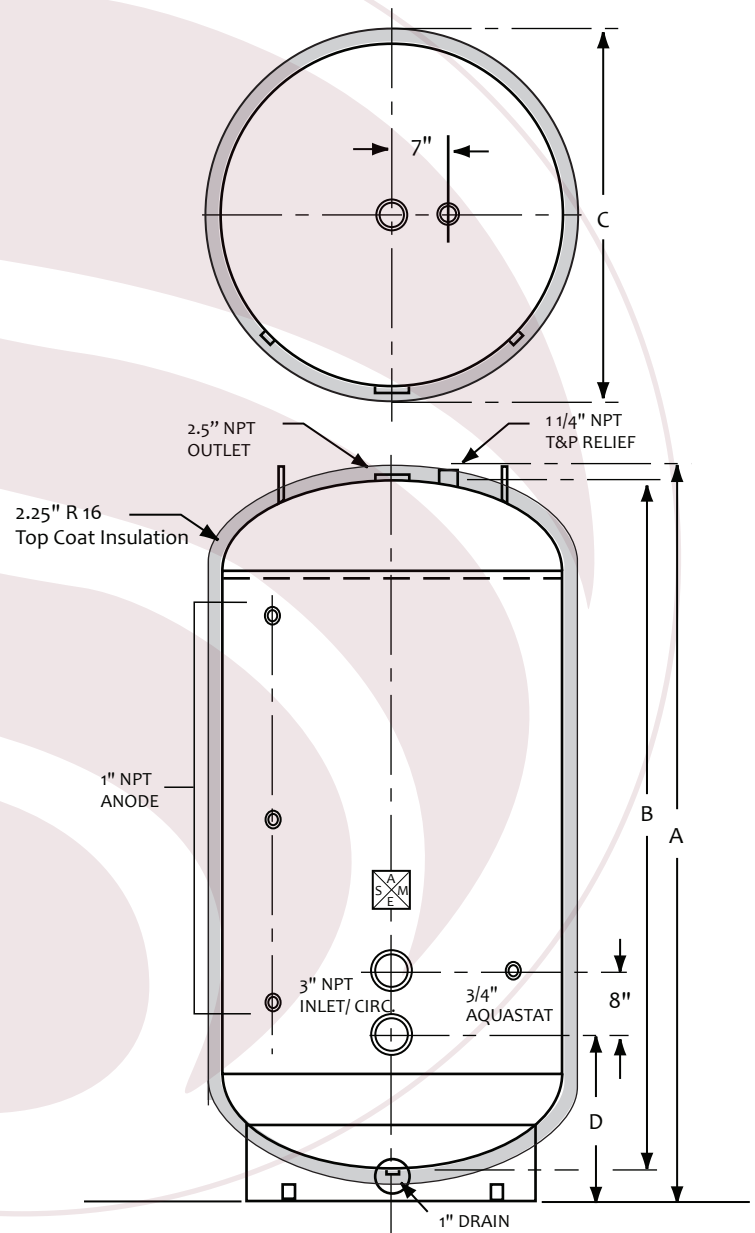

VERTICAL STORAGE TANK w/ topcoat insulation