



NST
NILES
STEEL
TANK
SINCE 1898

MODEL # BH-36-102

Design Notes

Code..... ASME Sec IV HLW
 Design Pressure..... 125 psi
 Test Pressure..... 125 psi
 Interior..... Ultonium Glass Lining
 Exterior..... Primed Painted
 Supports..... Saddles
 Capacity..... 415 Gal. / 449 nominal
 Weight..... 768 Lbs.

Material Specifications

Heads..... Carbon Steel
 Shell..... Carbon Steel
 Couplings..... Carbon Steel
 Flanges..... N/A
 Pipe..... N/A
 Manway..... N/A

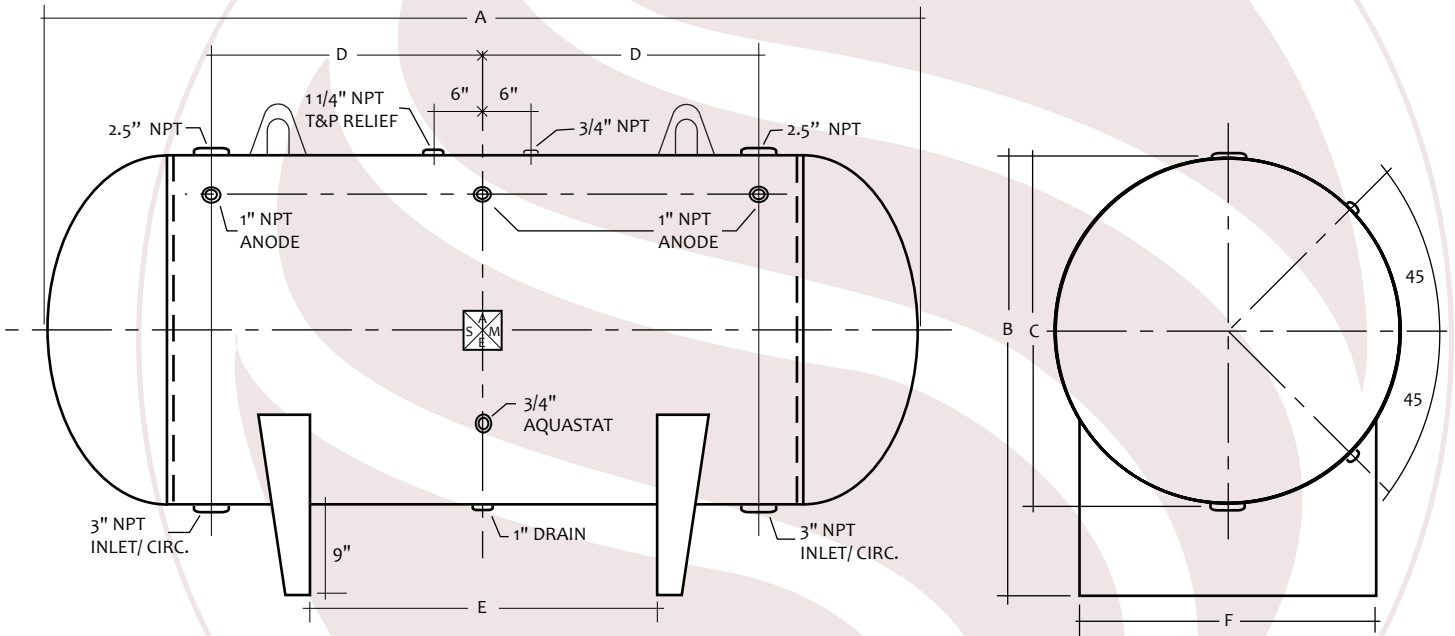

HORIZONTAL STORAGE TANK

Mark	Dimension	Remark
A	102"	Overall length
B	45"	Overall height
C	36"	Diameter
D	36"	Circulation
E	48"	Supports
F	31.69"	Support width

NOTES
PROJECT
CUSTOMER
SCALE Not to Scale
DATE
CUSTOMER P.O. #
DRAWING Rev NO.