



**NST**  
**NILES**  
**STEEL**  
**TANK**  
SINCE 1898

# MODEL # S-24-062A

## Design Notes

Code..... ASME Sec IV HLW  
 Design Pressure..... 150 psi  
 Test Pressure..... 150 psi  
 Interior..... Ultonium Glass Lining  
 Exterior..... Primed Painted  
 Supports..... Sits on Shell  
 Capacity..... 119 Gal.  
 Weight..... 225 Lbs.

## Material Specifications

Heads..... Carbon Steel  
 Shell..... Carbon Steel  
 Couplings..... Carbon Steel  
 Flanges..... N/A  
 Pipe..... N/A  
 Manway..... N/A

Mark	Dimension	Remark
A	62"	Overall height
B	55 7/8"	Relief
C	24"	Diameter
D	13 13/16"	Circulation
E	8 13/16"	Circulation
G	4 5/16"	Drain

NOTES	
PROJECT	
CUSTOMER	
SCALE	Not to Scale
DATE	
CUSTOMER P.O. #	
DRAWING Rev NO.	

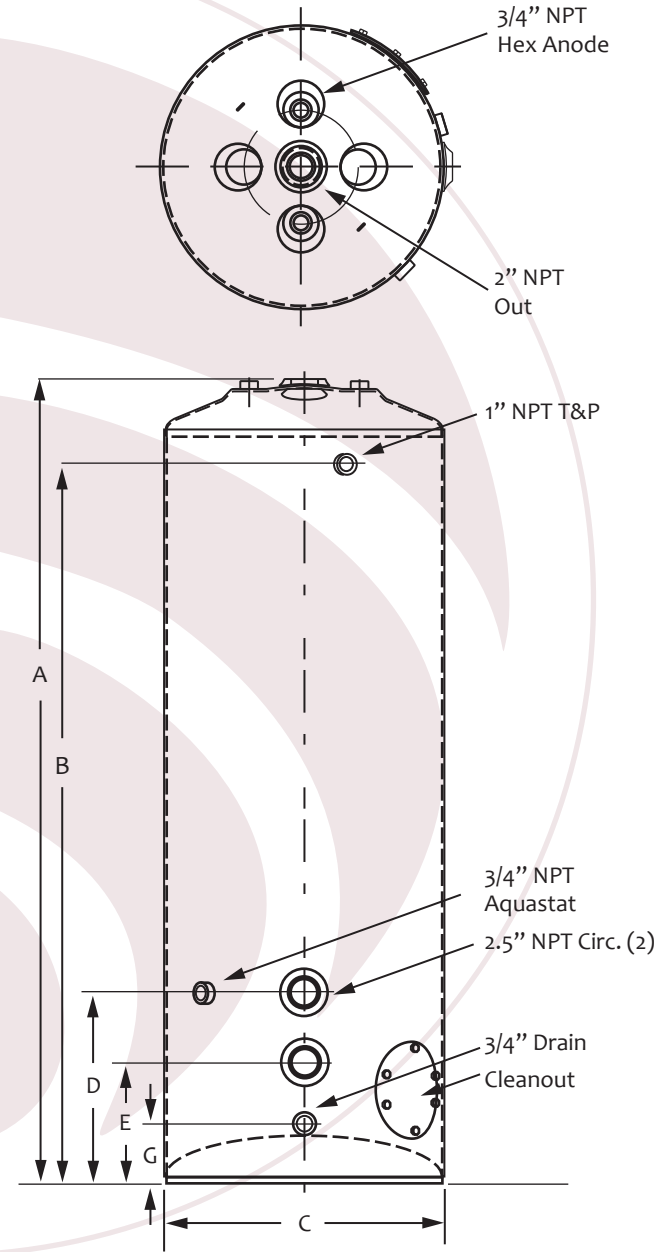

VERTICAL STORAGE TANK