



NST
NILES
STEEL
TANK
SINCE 1898

MODEL # BH-72-100

Design Notes

Code..... ASME Sec IV HLW
 Design Pressure..... 125 psi
 Test Pressure..... 125 psi
 Interior..... Ultonium Glass Lining
 Exterior..... Primed Painted
 Supports..... Saddles
 Capacity..... 1538 Gal. / 1761 nominal
 Weight..... 2942 Lbs.

Material Specifications

Heads..... Carbon Steel
 Shell..... Carbon Steel
 Couplings..... Carbon Steel
 Flanges..... N/A
 Pipe..... N/A
 Manway..... Carbon Steel

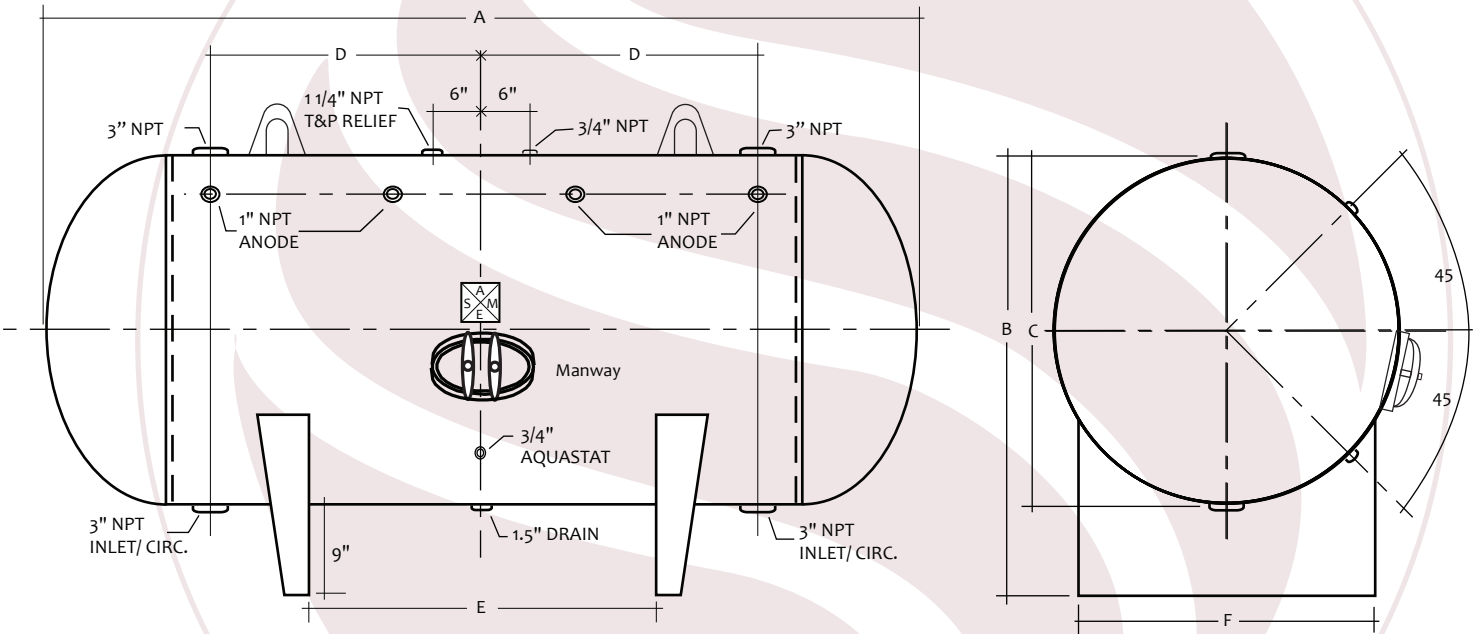

HORIZONTAL STORAGE TANK

| Mark | Dimension | Remark |
|------|-----------|----------------|
| A | 100" | Overall length |
| B | 81" | Overall height |
| C | 72" | Diameter |
| D | 26" | Circulation |
| E | 39.5" | Supports |
| F | 63" | Support width |

| NOTES | |
|-----------------|--------------|
| PROJECT | |
| CUSTOMER | |
| SCALE | Not to Scale |
| DATE | |
| CUSTOMER P.O. # | |
| DRAWING Rev NO. | |