



**NST**  
**NILES**  
**STEEL**  
**TANK**  
SINCE 1898

# MODEL # BH-42-129

## Design Notes

Code..... ASME Sec IV HLW  
 Design Pressure..... 125 psi  
 Test Pressure..... 125 psi  
 Interior..... Ultonium Glass Lining  
 Exterior..... Primed Painted  
 Supports..... Saddles  
 Capacity..... 720 Gal. / 774 nominal  
 Weight..... 1167 Lbs.

## Material Specifications

Heads..... Carbon Steel  
 Shell..... Carbon Steel  
 Couplings..... Carbon Steel  
 Flanges..... N/A  
 Pipe..... N/A  
 Manway..... Carbon Steel

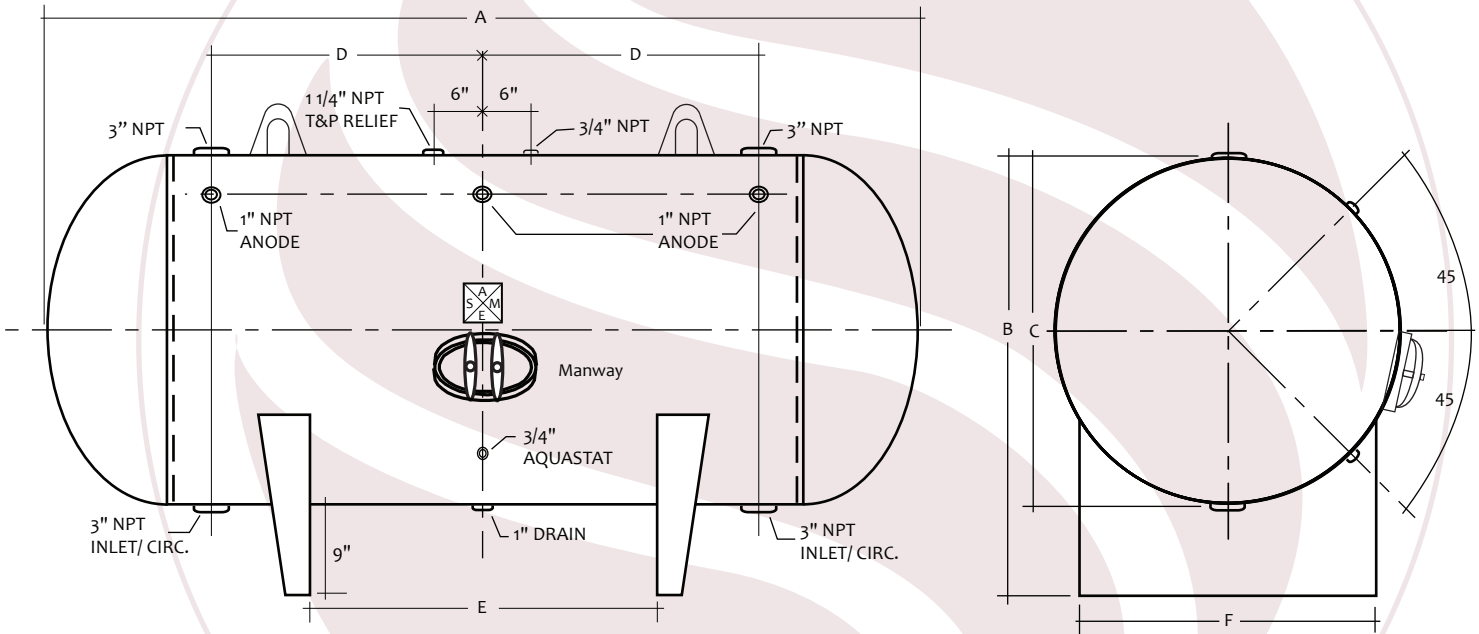

HORIZONTAL STORAGE TANK

Mark	Dimension	Remark
A	129"	Overall length
B	51"	Overall height
C	42"	Diameter
D	48"	Circulation
E	72"	Supports
F	36.75"	Support width

NOTES	
PROJECT	
CUSTOMER	
SCALE	Not to Scale
DATE	
CUSTOMER P.O. #	
DRAWING Rev NO.	