

**NST**  
**NILES**  
**STEEL**  
**TANK**  
SINCE 1898

1701 Terminal Road  
 P.O. Box 728  
 Niles, MI 49120  
 PHONE 269-683-1910  
 FAX 269-683-1953  
 www.nilest.com

A SUBSIDIARY OF BRADFORD WHITE CORPORATION

**Design Notes**

Code	ASME Sec IV HLW
Design Pressure	125 psi
Test Pressure	125 psi
Heads	1/4" 414G
Shell	1/4" 516 Grade 70
Interior	Ultonium Glass Lining
Exterior	Primed Painted
Radiograph	None
Capacity	1225 Gal. / 1306 nominal
Tare Weight	12056 Lbs.
Supports	Skirt

**Material Specifications**

Heads	Carbon Steel
Shell	Carbon Steel
Couplings	Carbon Steel
Flanges	
Pipe	
Manway	
Lining	Ultonium Glass

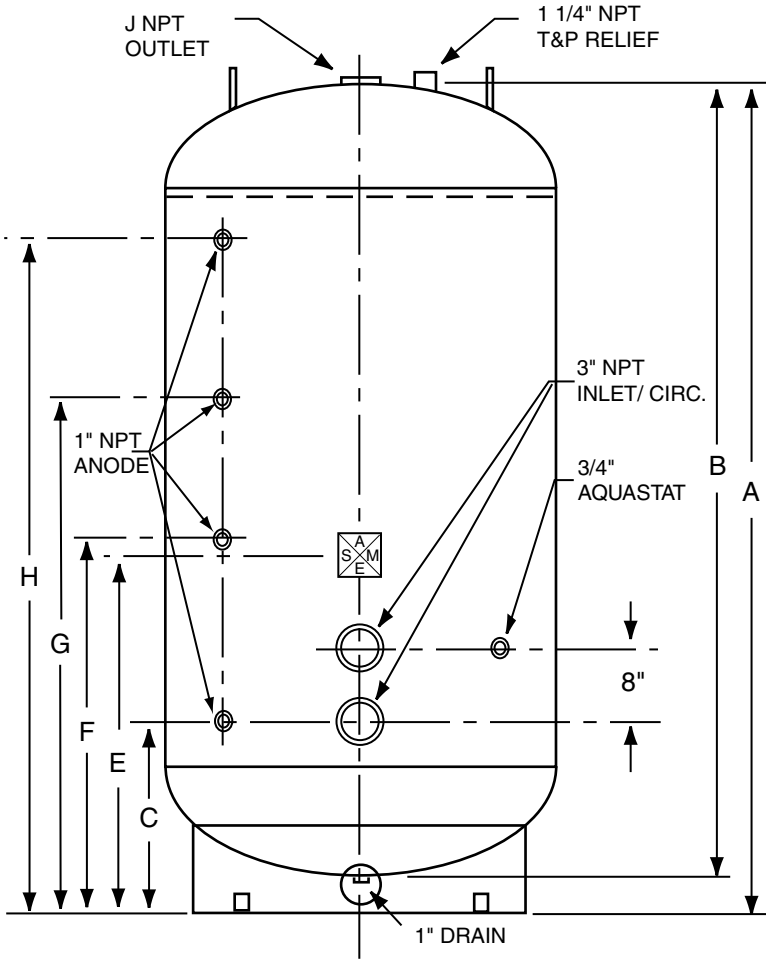

VERTICAL STORAGE TANK

Mark			
A	172"	Overall height	
B	168"	Tank height	
C	22"	Circulation	
D	48"	Diameter	
E	40.5"	ASME Plate	
F	55"	Anode	
G	94"	Anode	
H	127"	Anode	
J	3"	Hot Out	
	1"	Drain	

**NOTES**

**PROJECT**

CUSTOMER	
SCALE	Not to Scale
DATE	
CUSTOMER P.O. #	
DRAWING NO.	S-48-168