



NST
NILES
STEEL
TANK
SINCE 1898

1701 Terminal Road
 P.O. Box 728
 Niles, MI 49120
 PHONE 269-683-1910
 FAX 269-683-1953
 www.nilesst.com

A SUBSIDIARY OF BRADFORD WHITE CORPORATION

Material Specifications	
Heads	Carbon Steel
Shell	Carbon Steel
Couplings	Carbon Steel
Flanges	
Pipe	
Manway	
Lining	Ultonium Glass

Design Notes	
Code	ASME Sec IV HLW
Design Pressure	125 psi
Test Pressure	125 psi
Heads	1/4" 414G
Shell	1/4" 516 Grade 70
Interior	Ultonium Glass Lining
Exterior	Primed Painted
Radiograph	None
Capacity	1225 Gal. / 1306 nominal
Tare Weight	2,126 Lbs.
Supports	Saddles

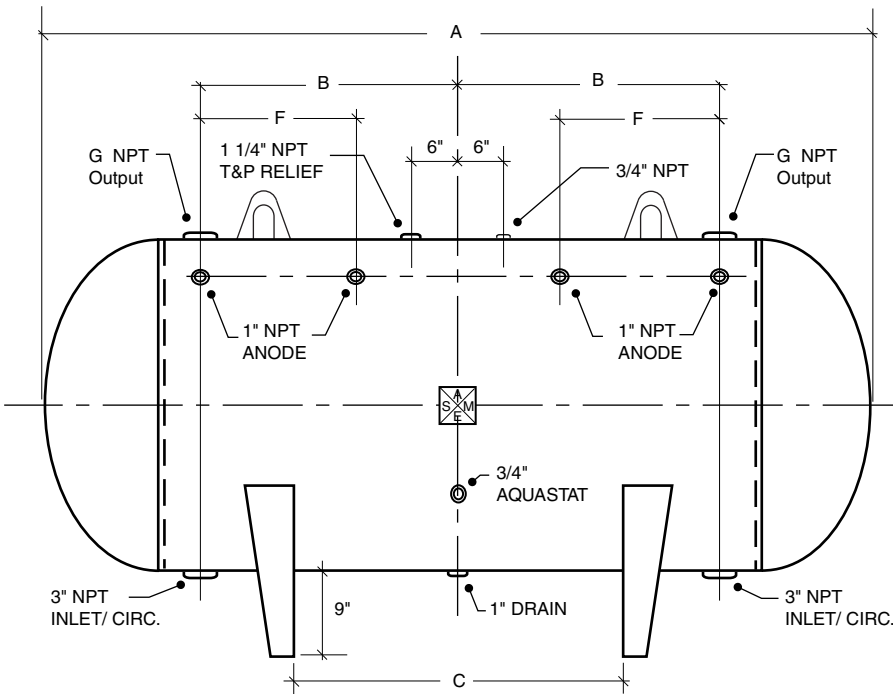

Mark			
A	168"	Overall Length	
B	66"	Circulation	
C	108"	Supports	
D	48"	Diameter	
E	42.13"	support width	
F	33"	Anode	
G	3"	Hot Out	
H	57"	Height	

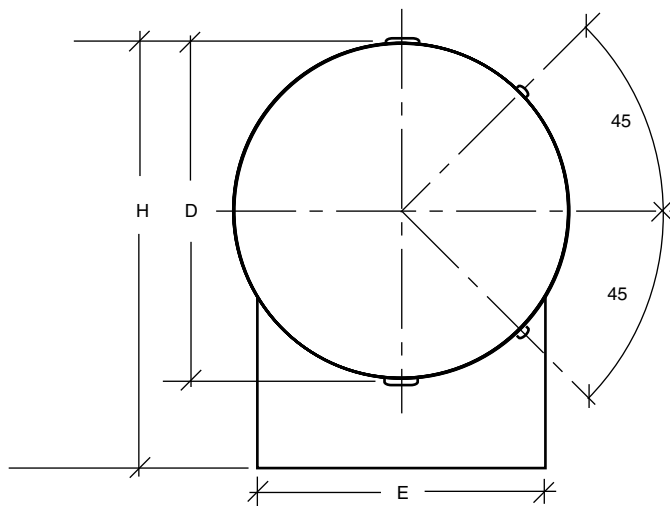

PROJECT	
CUSTOMER	
SCALE	Not to Scale
DATE	
CUSTOMER P.O. #	
DRAWING NO.	BH-48-168

NOTES