

# CHILLED WATER BUFFER TANKS

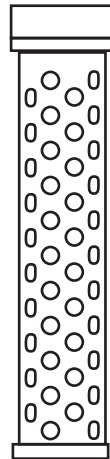

**NST**  
**NILES**  
**STEEL**  
**TANK**  
 SINCE 1898™

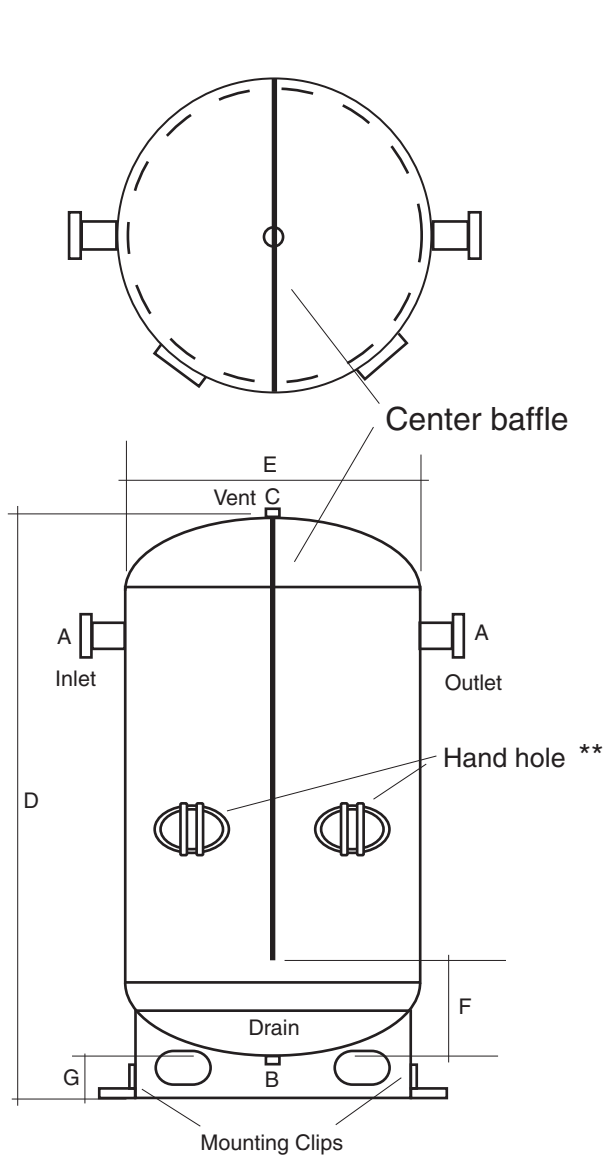

**Sparge tube**  
 disperses water evenly

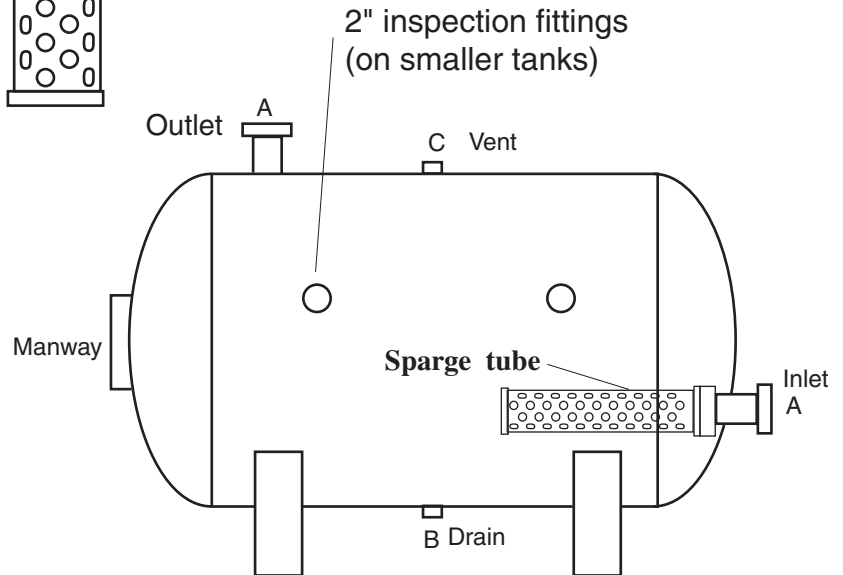

**Inlets and outlets can be positioned in the shell of the tank if required.**

**All tanks are constructed and certified in accordance with ASME section VIII, Div. I code**

**Spray foam insulation available, R-16 value**

**Red oxide shop primer exterior**

**Custom sizes available upon request**

**Designed to ASME code**

**Sparge tube is shipped loose.**

\*\* Hand holes required on tanks above 36" diameter

Model	Gal.	A	B	C	D	E	F	G	Wt/ Lbs
CBT-24-072	130	2 NPT	1"	1"	78"	24"	20"	6"	375
CBT-30-075	210	3 Flg	1"	1"	83"	30"	24"	6"	425
CBT-36-078	300	4 Flg	1"	1"	78"	36"	24"	6"	633
CBT-36-094	400	4 Flg	1"	1"	100"	36"	30"	6"	715
CBT-42-085	500	4 Flg	1"	1"	90"	42"	28"	6"	1250
CBT-48-077	528	6 Flg	1"	1"	83"	48"	31"	6"	1150
CBT-54-096	850	6 Flg	1"	1"	102"	54"	32"	6"	1630
CBT-60-096	1040	8 Flg	1"	1"	102"	60"	32"	6"	2280

1701 Terminal Road  
 PO Box 728  
 Niles, MI 49120  
 Phone - 269-683-1910  
 Fax - 269-683-1953  
 www.nilesst.com